

CHAPTER 5

FIXED STRUCTURE MONITORING STATIONS

5.1 INTRODUCTION

There are many types of fixed structures that can be used to place or fasten the monitoring sondes at a fixed position from the bottom substrate. In this section, three categories of fixed structures are described (Figure 5.1):

- DESIGNED PLATFORM
- EXISTING STRUCTURE
- ON RIVER & STREAM BANK STRUCTURE

As explained in the Preface, research has shown that most of the project's life-cycle quality and cost are committed by the decisions taken by the end of the planning and design stages.

One of the best practices employed to improve quality, prevent errors, and minimize cost is by adapting or reviewing during the planning and design stages known techniques or processes that have shown through experience to achieve the desired result in a reliable, efficient, and effective way.

Design and construction guidelines are provided in this chapter to facilitate an understanding of the different station design requirements and to support and guide the monitoring team during the monitoring platform selection process.

The following guidelines are provided:

→ FOR DESIGNED PLATFORM:

- Detail guidelines: Antenna Tower-PVC; Antenna Tower-Wood; and Wood.
- General guidelines: PVC, pile and underwater structures.

→ FOR EXISTING STRUCTURE:

- General construction guidelines: pier and pile structures.

→ FOR ON RIVER & STREAM BANK STRUCTURE:

- General construction guidelines: on river & stream bank structures without equipment shelter.

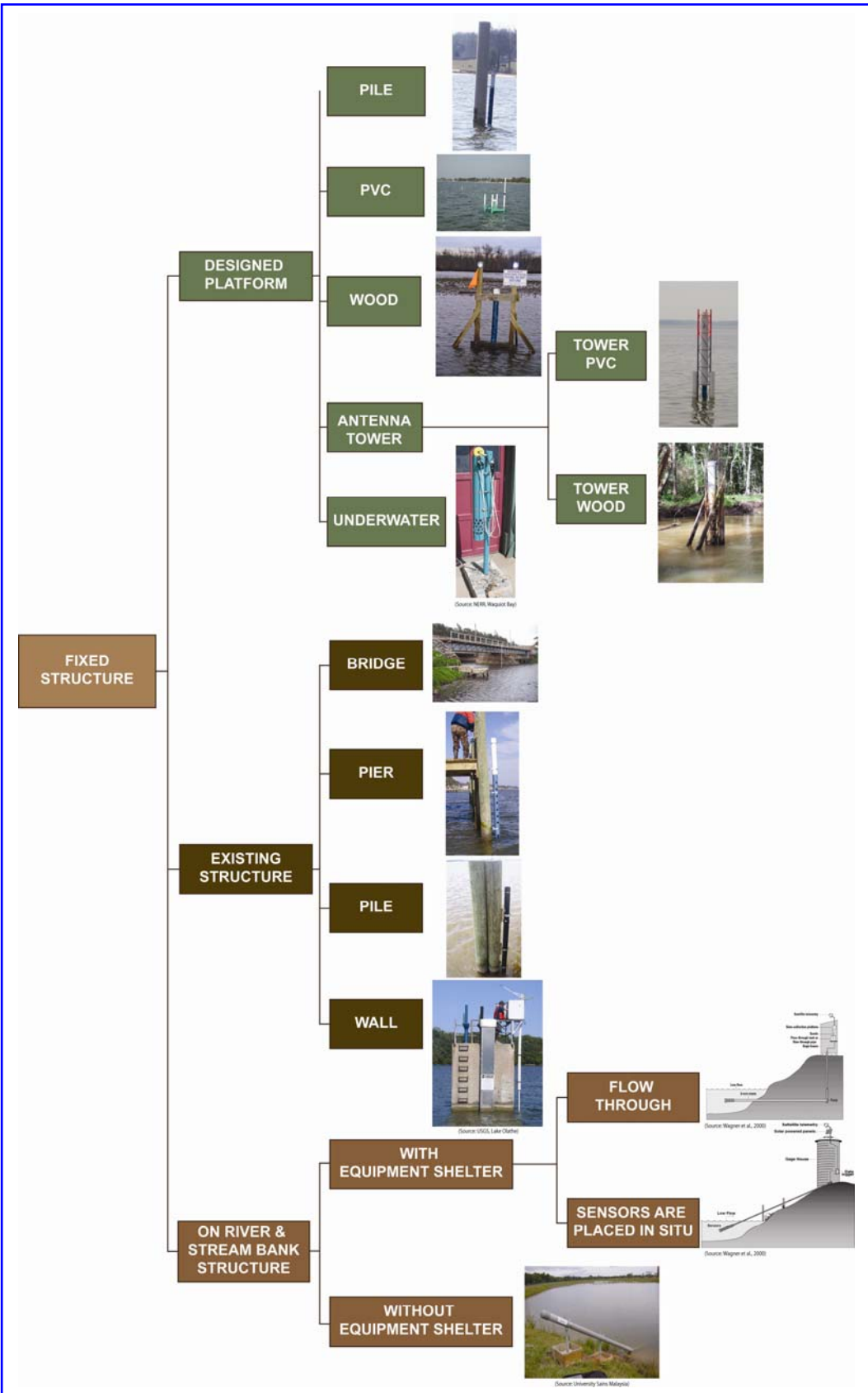

Figure 5.1 Fixed shallow water continuous monitoring structures

5.2 DESIGNED PLATFORM: PILE

5.2.1 Introduction

A general overview of pile foundations is provided here as an introduction. A more detail description can be found in Collin 2002; Department of the Army, 1985; Gerwick, 2000; Tomlinson, 1994; and US Army Corps of Engineers, 1998, 2003.

The pile monitoring station is the most basic type of designed platform (Figure 5.2). A pile is a long column usually made of steel, reinforced concrete, pressure treated timber, or PVC that is driven into the ground to support the monitoring equipment. One possible classification of piles is: by the way in which they transmit their load to the ground; and by the way in which they are installed (The Hong Kong Polytechnic University; Abebe and Smith, 2005).

- **Transmission of Load to the Ground:** Bearing or friction piles (Figure 5.3).

Bearing Pile: A pile which rests its base on a relatively firm stratum of good bearing capacity such as rock, very dense sand or gravel. These piles transfer their load onto the firm stratum located at a considerable depth below the base of the structure.

Friction Pile: A pile which rests on a stratum of limited bearing capacity[¶] and provides its support through friction resistance along the lateral surface of the pile. The pile transmits the load of the structure to the penetrable soil by means of skin friction or cohesion between the soil and the embedded surface of the pile.

- **Installation Method:** Displacement or replacement piles.

Displacement Pile: The pile is driven or vibrated into the ground, and the soil is displaced downwards and sideways. To develop adequate frictional resistance, the pile is driven far enough into the lower substrate.

Replacement Pile: The pile is placed or constructed in a previously drilled borehole.

Most commonly, displacement friction piles are employed for continuous shallow water quality monitoring projects. The main reason for using this type of pile is that bearing piles are more expensive to use. Usually the firm stratum is at a considerable depth; therefore, a longer pile and special installation equipment will be needed.

The bearing capacity of the pile is determined by the weight of the: pile, guard-pipe, and monitoring and telemetry equipment.

[¶] The bearing capacity of a pile is the load which can be sustained by a pile without producing excessive settlement or material movement (Shroff and Shah, 2003).

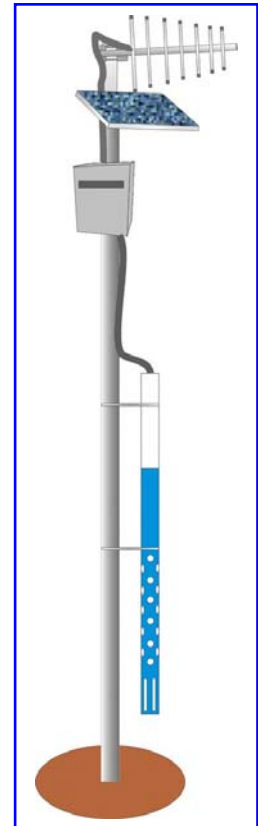

Figure 5.2 Sketch of a piling monitoring structure

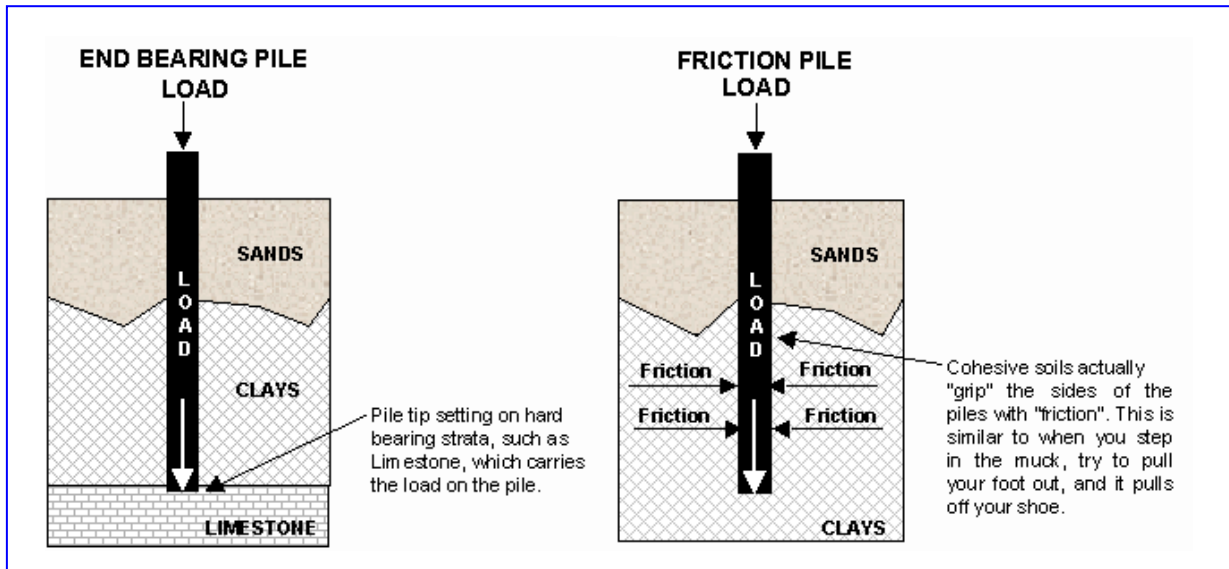

Figure 5.3 Sketch of bearing and friction piles (Source: FHWA, 2007)

5.2.2 Construction Guidelines

The site-specific and pile characteristics would determine if it is better to hire a professional marine piling driving company or perform the installation in-house.

An outline of design and construction considerations follows.

Site Characterization: the type of substrate at the monitoring site must be assessed. The type of soil will define the installation method and the minimum penetration depth to assure adequate lateral support.

Pile Material: generally, pile material consists of pressure treated timber, PVC, steel, or reinforced concrete. In terms of accessibility, cost, and ease of installation, pressure treated piles and PVC pipes are the materials of choice.

If a PVC pipe is employed, it is good practice to fill the pipe with concrete or sand and gravel to increase moment capacity.

For shallow water quality monitoring projects, the materials of choice are:

- **Pressure-treated wood:** Round timber piles (6 to 9 inch diameter – 14 to 20 feet long) or Posts (4"x6", 6"x6").
- **PVC:** Schedule 40; 6 to 10 inch pipe size diameter.

Note: During the pressure treatment process, preservative is added to the wood. The retention levels (expressed in terms of pounds of preservative per cubic foot of wood) refer to the amount of chemical preservative retained in the wood cell structure after the pressure process has been completed. The higher the retention level, the harsher the conditions that wood can be exposed to (Osmond *et al.*, 2003).

Application	Required Retention (pcf)
Fresh Water	0.80
Salt Water Immersion	2.50

Standards of the American Wood-Preservers' Association (www.awpa.com)

Installation Method: two basic installation methods exist for driving the pile into the soil; hammering or jetting (FHWA, 2007; Abebe and Smith, 2005).

- Hammer types include; drop, single acting air/steam, double acting air/steam, diesel or hydraulic or diesel with built-in energy measurement.
 - To drive timber piles use only gravity hammers.
 - Depending on the job, renting a small pile driving barge or portable marine pile driving equipment can be a good choice.



Figure 5.4 Drop hammer
(Source: Whatcom Waterfront Construction)



Figure 5.5 Small pile driving work barge
(Source: ASD Pty Ltd., Marine Pile Drivers)

- Jetting is the process of using water under pressure to erode the soil in order to aid the penetration of the pile. Jetting has very limited effect in firm to stiff clays or any soil containing much coarse gravel, cobbles, or boulders.

For shallow waters a jetting system can easily be assembled; basically, it consists of the following equipment:

<p>Water pump</p> <p>There are a variety of water pumps that would work well for jetting piles.</p> <p>A 2 inch 3 ½ to 5 ½ HP transfer pump with maximum flows from 145 to 200 gpm at maximum pressure of 40 to 50 psi works well in most shallow water environments.</p>	
<p>Couplings, pipe fittings, and valves to connect the jetting assembly to the water pump.</p>	
<p>Discharge and suction hoses (or PVC suction pipe).</p>	
<p>Jet pipes; Pipe and hose fittings</p>	

NOTE

- The installation method will be determined by the type of pile material, length of the pile, substrate characteristics, and the monitoring objectives (the station platform must comply with the monitoring objectives; thus, it is possible that the only way to ensure the monitoring objectives is to use a certain pile structure that requires a drop hammer to install).
- Care must be taken if jetting will be used to install the pile in a sea grass bed. The high-pressure water disturbs the adjacent vegetation and sediments, and could cause irremediable damage to the sea grass adjacent to the construction area (Kelty and Bliven, 2003).

Deployment Tips

• Pile Preparation:

- The pile must be inspected and cut (if needed) before installation.
- It is a good practice for timber piles to cut or trim the bottom of the pile to a cone or inverted pyramid shape. This will ease the pile penetration. For hard substrates, a pile shoe may be used to protect the pile-tip from damage during driving.
- It is a good practice, if the pile has different diameter size (top – end), to place the larger size as the end, and cut or trim this end. If the water freezes during winter, this may help to prevent the ice from lifting the pile out of the ground.
- If hammering is used, it is a good practice to place steel bands or pipe clamp at the top to prevent splitting. If a sledge hammer is used for hammering, duck tape can be used to wrap the top part of the pile to increase its shock resistance.
- If hammering is not used, and the pile will use an antenna tower to support the telemetry equipment; the antenna tower may be installed on land.



Figure 5.6 View of pile bottom



Figure 5.7 View of pile with the antenna tower mounted on land

- **Hammering:** Usually hammering will be needed to drive the wooden post or PVC pipe into the substrate. In most situations, a sledge hammer will be enough to do the job.
 - Hammer cushions must be used to protect the PVC pipe or wooden post.
 - Cushions must not be too hard because they may cause pile damage. Commonly cushion are made of hardwood, plywood, woven steel wire, laminated micarta and aluminum discs, and plastic laminated discs (US Army Corps of Engineers, 1998).
 - A piece of treated lumber (2" by 4" or 2" by 6") makes a good cushion.
- **Jetting:** Jetting may be used alone or may be needed to help the hammering process to aid the penetration of the pile into the bottom substrate.

- It is good practice to make first a hole where the pile will be installed; this will ease the driving process, specially standing up the pile. It is important not to make the hole to big, to assure that sufficient resistance will be encountered by the pile as it is driven (adequate bearing power is develop).
- During the jetting process, the best results are obtained when the water jet is close to the pile bottom and the jet is moved around the pile (to keep the pile in a straight position).
- Moving the jet pipe up and down along the pile can help the driving process.

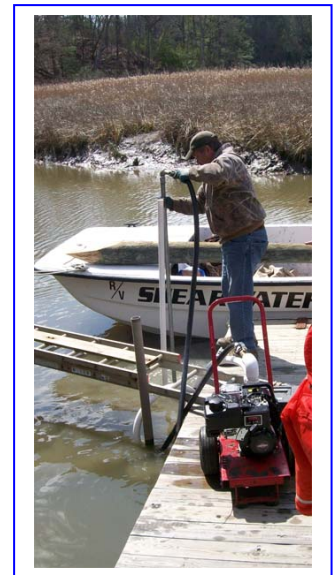

Figure 5.8 Jetting initial hole



Figure 5.9 Jetting process

- Do not leave the jet pipe standing still while jetting, it can easily get stuck.
- In hard substrates, turning the pile as it is being jetted may ease the pile driving process. Some kind of pipe clamp (L-clamp or a large C-clamp) can be used as a support to twist the pile.
- It is a good practice to mark the pile and the jet pipe to ensure the pipe is hold at the same depth as the bottom of the pilling.
- PVC pipes can be driven either open end or closed end. When driven open end, the soil will enter by the bottom of the pipe. If needed, to empty the pipe the water jet can be used.

- **Penetration Depth**

- It is a good practice to mark the pile to ensure the desired penetration depth is reached.

Even though the penetration depth depends on several factors, as a rule of thumb, the pile must be driven a minimum of one third of its height. The pile must be tight and secure before the installation process is stopped.

- **Guard-Pipe Holding System**

- Any type of pipe hanger device can be used to secure the guard-pipe to the pile. For example, clevis or conduit hangers are commonly employed (Figure 5.11).

→ Some distance must be kept between the guard-pipe and the structure to minimize possible effects produced by the structure to the water quality data (*i.e.* seaweeds or any other type of biofouling growing on the structure).



Figure 5.10 Pile station waiting for the guard-pipe to be placed.



Figure 5.11 Clevis and Conduit Hangers



Figure 5.12 View of different methods used to attach the guard-pipe to the pile.

Some advantages of the pile structure monitoring platform are: it is easy to construct, can be used in almost any type of shallow water monitoring environment, and it is a good platform alternative when the monitoring endeavor is for a very short period of time.

Some disadvantages of this type of structure are: 1) The station stability depends on two factors; the penetration depth and the pile material's strength; soft substrate environments may require large penetration depth, making it less cost-effective; 2) Special equipment may be needed to drive the piling into the ground to achieve the necessary penetration depth to ensure station stability; 3) Readily available PVC pipes in general come in 16 ft (4.9 m) length. To achieve adequate heights above the water level, pipes may be necessary to glue together, producing weak points in the structure.



Figure 5.13 View of different pile platforms
(Source: CBNERRVA, South Slough NERR, Rookery Bay)

5.3 DESIGNED PLATFORM: PVC STRUCTURES

PVC structures can be seen as Lego type structures given the great variety of existing PVC fittings, pipes, and accessories. In this section two basic PVC structures are given as guideline only; a two and a four leg structures.

5.3.1 Two Leg PVC Structure

The two-leg PVC monitoring station is constructed by driving two PVC pipes into the soil. These pipes are used as the platform frame. Two transverse PVC pipes are employed to fasten the two legs together and to hold the sensor guard in position (Figure 5.14).

Construction Material: schedule 40; 6 to 10 inch pipe size diameter.

The transverse PVC pipes can be coupled to the legs by: tee fittings; by drilling a hole in each leg and gluing the transverse PVC pipes to each leg; or by using some kind of pipe fastener device (Figure 5.15).

The guard-pipe can be fastened to the transverse PVC pipes by using double tees or some kind of pipe fastener device, such as a U bolt (Figure 5.16).

If double tees are employed to secure the guard-pipe to the transverse PVC pipes, a system of bolts and double-nuts can be used as shown in Figure 5.17 and 5.18.

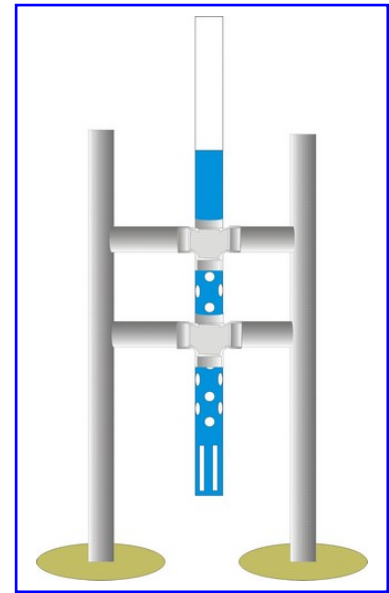

Figure 5.14 Sketch of a two-leg PVC structure



Figure 5.15 The Transverse PVC is fastened to the structure leg by a U-Bolt



Figure 5.16 The guard-pipe is fastened to the transverse PVC by a U-bolt

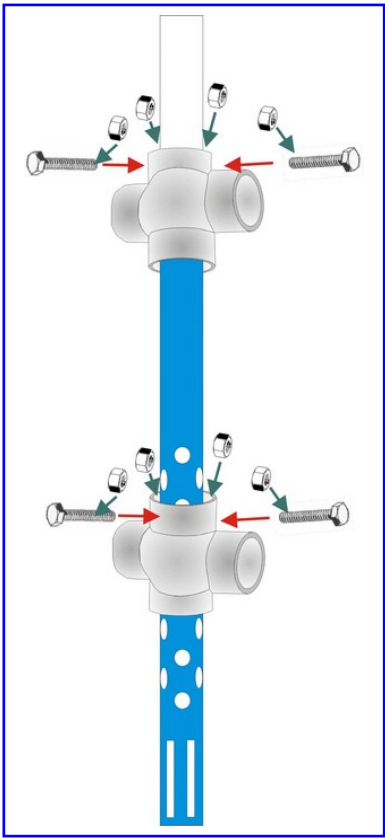

Figure 5.17 Sketch of a guard-pipe fastened to double tees using a bolt and double-nut holding system

Advantages of PVC Structures:

- Given the multiple PVC fittings and pipes in the market, a specific structure to fit most monitoring needs can be easily built.
- Simple construction
- Can be used in almost any environment

Disadvantages of PVC Structures:

- Care must be taken during construction so that each piece fits together
- Every glued joint is a weak point

Using the same design principles, other types of material could be used (*e.g.* galvanized structures, Figure 5.19). Galvanized pipes are more expensive than PVC, but they have higher yield strength, and therefore can be more suitable for certain types of monitoring environments.



Figure 5.18 Close-Up view of a bolt-double nut

5.3.2 Four Leg PVC Structure

The four leg PVC structure consists of a four-piling PVC arrangement in a square layout (Figure 5.20). The four PVC legs are coupled together using transverse PVC pipes. These pipes, as the guard-pipe, are held in place by employing one of the fastening methods described in 5.3.1.

To increase structure stability, concrete or sand and gravel can be poured inside the legs.



Figure 5.19 Galvanized structure. USGS monitoring station.
(Source: Paul Perusse)

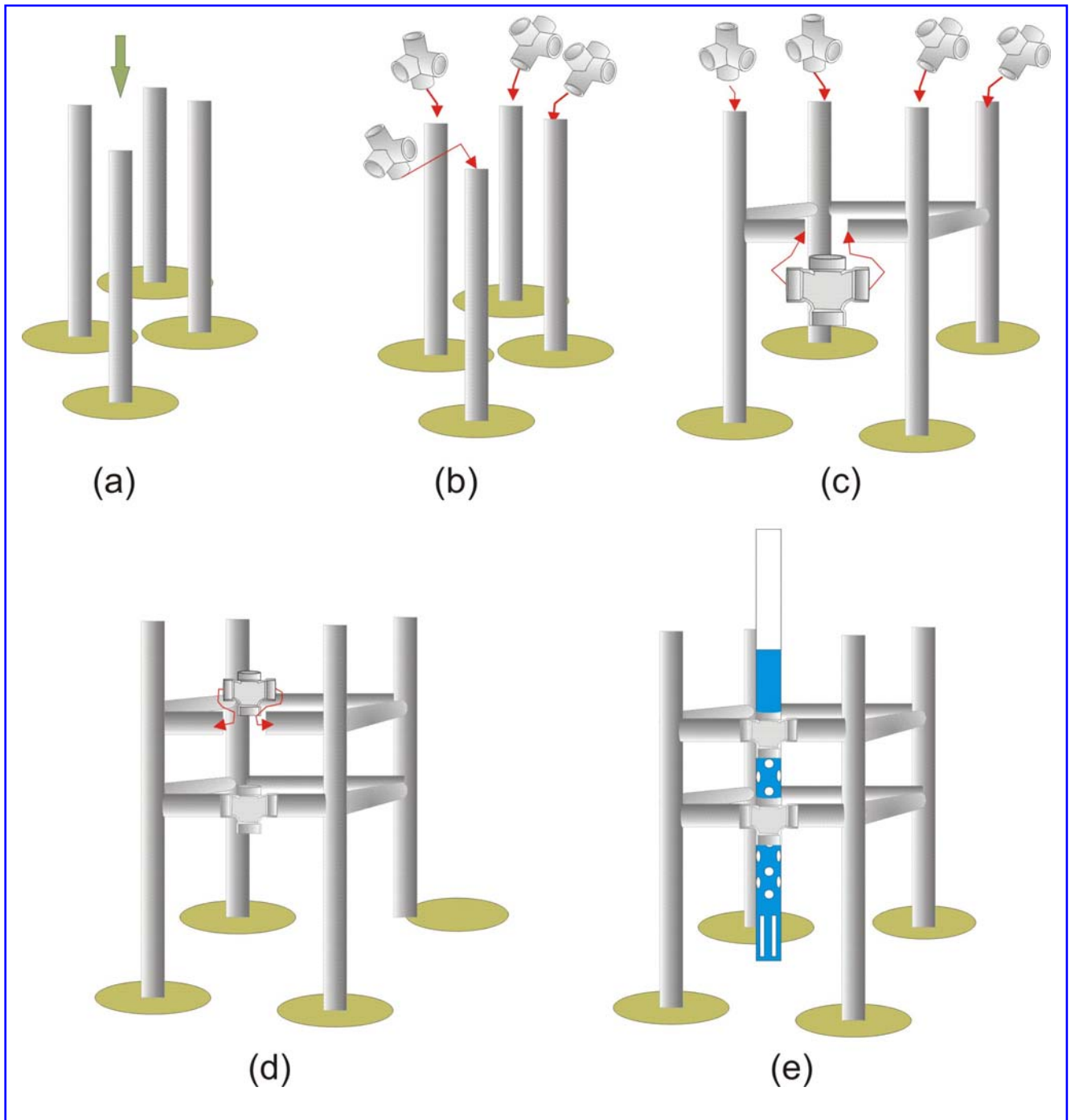

Figure 5.20 Sketch showing the construction steps of a four leg PVC structure

5.4 DESIGNED PLATFORM: UNDERWATER

Fixed underwater monitoring stations are commonly employed when:

- Local regulations prohibit the installation of an offshore permanent monitoring station (e.g. piling, large buoy).
- The risk of vandalism is high in the sampling area.
- The monitoring objectives require sampling close to the bottoms sediments and:
 - Minimal disturbance of the sampling area must be achieved; or
 - The project has multiple temporary monitoring points, and/or given the duration of the project this type of platform is the most cost-effective option.

To deploy the guard-pipe or monitoring sonde at a fixed distance from the bottom sediments two methods are commonly employed:

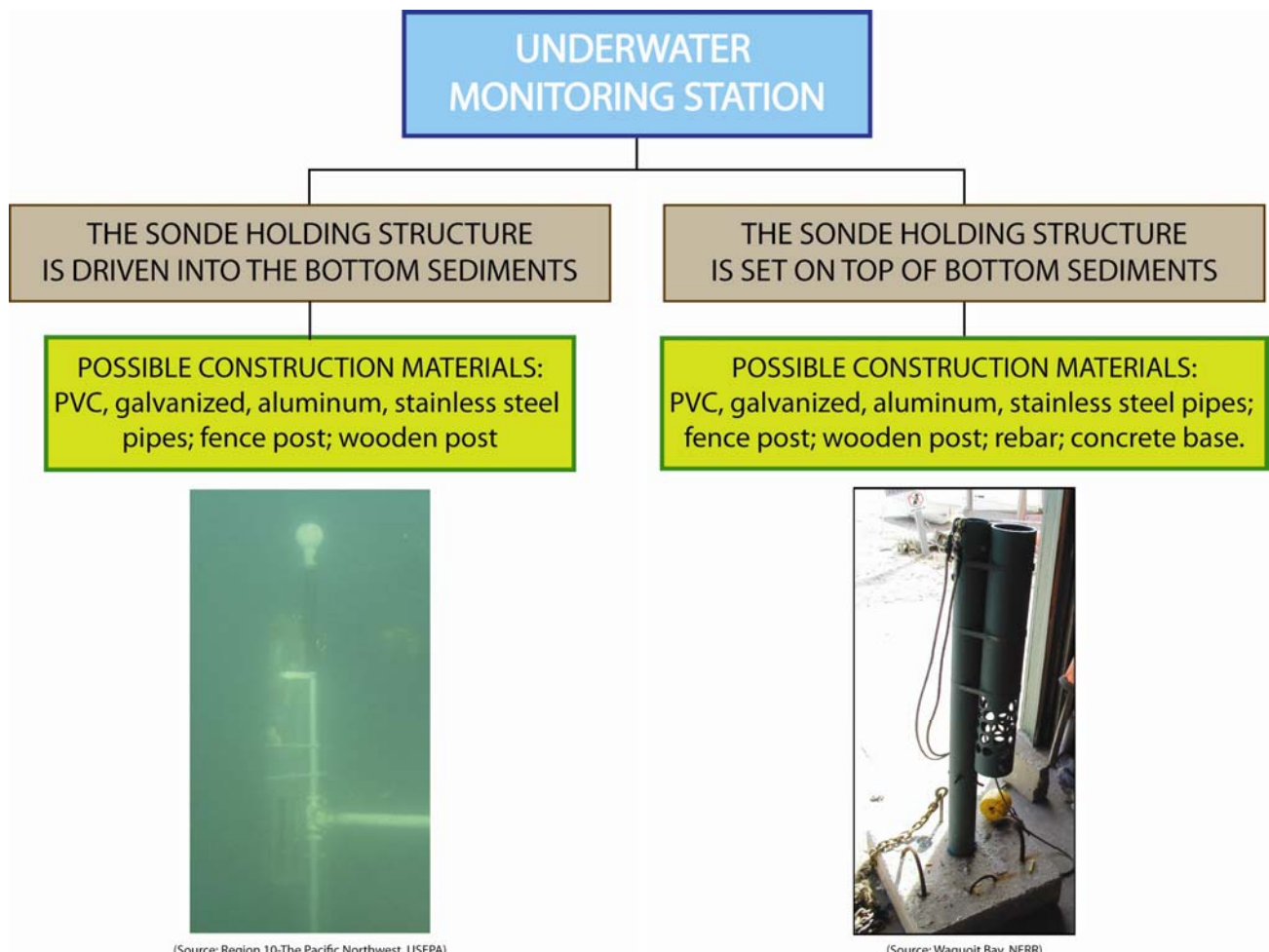

Figure 5.21 Underwater monitoring structures

In this section, construction guidelines are provided for an underwater monitoring structure designed at Waquoit Bay National Estuarine Research Reserve. These guidelines can be used as framework for designing other underwater structures.

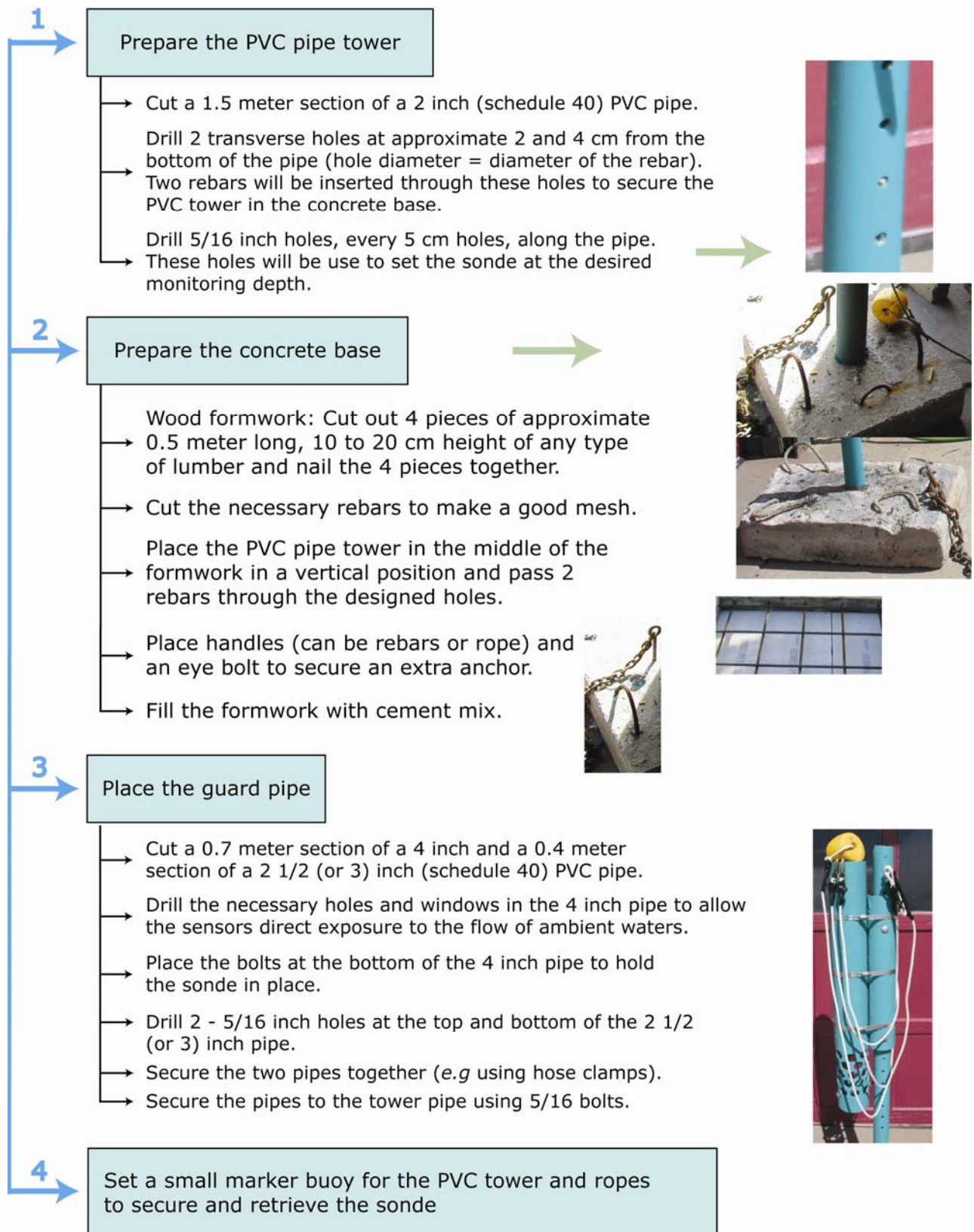



Figure 5.22 View of the station maker buoy attached to a round cement weight

A station marker buoy may be used if needed (Figure 5.22).

To secure the marker buoy:

- Attach one end of a chain (at least 2 meter long) to the eye bolt at the base of the station and the other end to an extra anchor (*e.g.* concrete block).
- Attach the maker buoy to the extra anchor.

The anchor will be placed at some distance from the base of the station to prevent the marker buoy to get entangled with the sonde's marker buoy or the PVC tower.

At Waquoit Bay NERR, this underwater platform is used in low water environments (*e.g.* at low tide, the water surface is around 0.3 meter from the top of the station. Tides in Waquoit Bay are semidiurnal with an average range of about 0.4 m). An advantage of this particular platform design is that the monitoring depth can be adjusted by moving the guard-pipe up or down the PVC tower. For example, at Metoxit Point, the monitoring depth is set at 0.7 m and at Sage Lot at 0.5 m from the bottom, respectively. This ensures that at Metoxit Point the sensors are above the macro algal mats and at Sage Lot Pond (a salt pond) the sensor are sufficiently into the water column and above the eelgrass bed.

5.5 DESIGNED PLATFORM: ANTENNA TOWER

The antenna tower is an excellent construction material to build offshore monitoring platforms: it has high strength, it is versatile to use with other construction materials, and it provides a good supporting structure to fasten the guard-pipe and telemetry equipment.

In this section, detail guidelines are provided for two antenna tower monitoring platforms.

The guidelines are written in a standard operating procedure style.

5.5.1 SUMMARY OF THE GUIDELINES

Two platforms constructed using 10 foot galvanized tower sections are described in this section (Figure 5.23). The main difference between these configurations is the type of material employed to construct the structure frame:

- The antenna tower platform with wooden columns is constructed by driving two 16-foot (4 by 4 inches) pressure treated wooden posts into the ground for use as the platform columns. To further increase the station stability, 16-foot (2 by 6 inches) boards are employed as diagonal beams to support the structure columns. The antenna tower is secured to the two wooden columns using two-hole tubing straps.
- The antenna tower platform with PVC columns is constructed by driving three schedule 40, 4 inch diameter pipes into the ground for use as the platform columns. The antenna tower is secured to the three PVC columns using U-bolts.

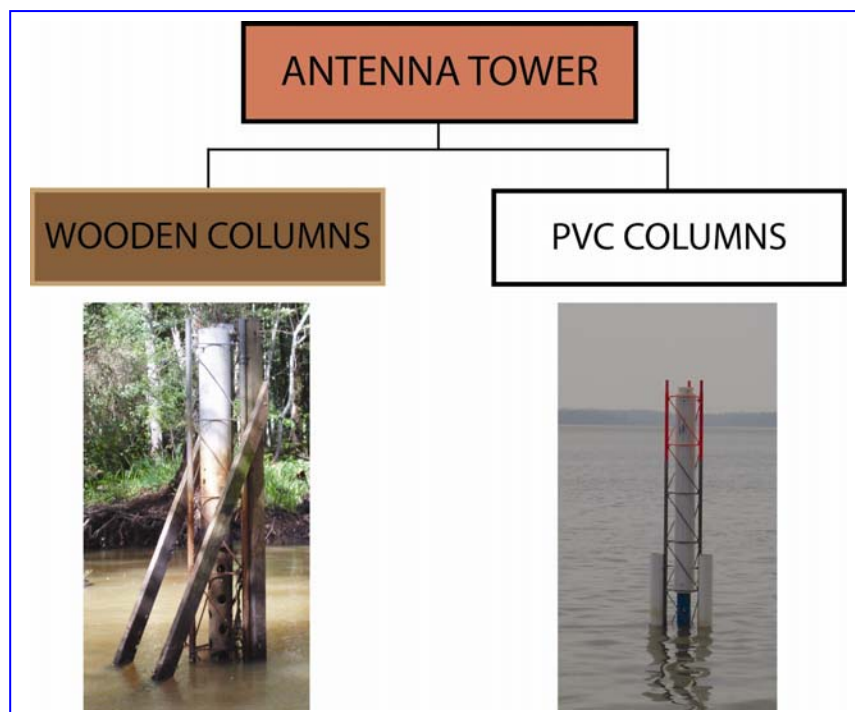

Figure 5.23 Antenna tower structures: wooden and PVC columns

The guard-pipe can be installed inside or outside the antenna tower:

- **If installed inside**, the guard-pipe is secured to a 6 inch PVC pipe that is inserted into the antenna tower.
- **If installed outside**, the guard-pipe is secured to the antenna tower by U-bolts.

These guidelines prescribe a specific design method to be followed. The requirements of these guidelines are subject to modification depending on the designer judgment.

5.5.2 QUALIFICATIONS & RESPONSIBILITIES

All users of these guidelines must be familiar with it before implementation and if necessary trained by personnel with previous experience in shallow water quality monitoring station construction.

5.5.3 HEALTH AND SAFETY WARNINGS

The construction of the monitoring structures requires precautions for safe handling and use of the tools and materials.

- General safety precautions for working with electric and power tools must be taken.
- When using power tools safety glasses must be used. When using circular saw earplugs must be used too.
- During field assembly, special care must be taken when using power tools, pumps, hammers, saws, or any other type of tools that can cause injuries. Adequate safety equipment must be used.
- Before field assembly, the construction team must go over the construction steps and safety requirements to assure each team member knows his/her responsibilities.

5.5.4 EQUIPMENT AND SUPPLIES

For assembly purposes, the antenna tower is divided into two parts: the tower system and the station frame (Figure 5.24).

The following equipment and supplies needed to:

- Prepare and assemble the tower system and station frame, and
- Deploy the monitoring platform

are listed in the following five sub-sections.

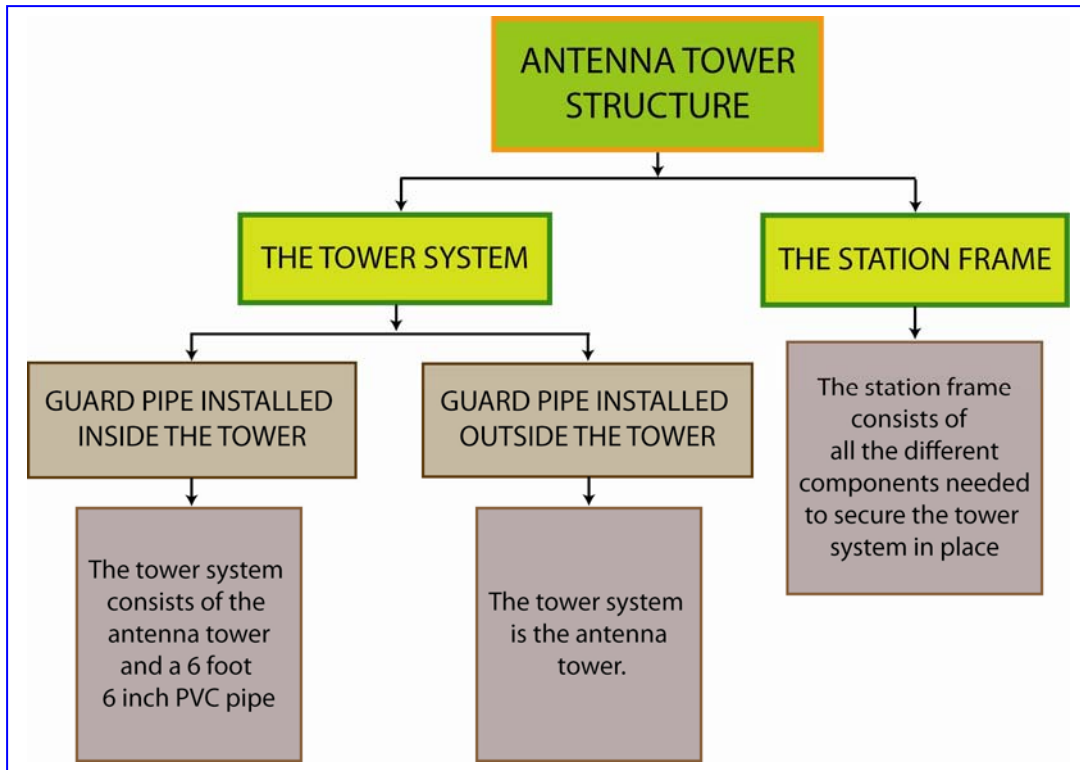

Figure 5.24 Antenna tower structure components

1. **Wooden columns:** equipment and supplies to construct the wooden columns on-land.
2. **PVC columns:** supplies needed for the PVC columns.
3. **Tower System – Guard-Pipe Installed inside the Antenna Tower:** equipment and supplies needed to construct and assemble the tower system on-land.
4. **Deployment Antenna Tower with Wooden Columns:** equipment and supplies needed to deploy the monitoring station at the site.
5. **Deployment Antenna Tower with PVC Columns:** equipment and supplies needed to deploy the monitoring station at the site.

Note: it is a good practice to take additional supplies, *e.g.* bolts, nuts, U-Bolts, *etc.*, in the event they are dropped in the water or break during the station deployment.

5.5.4.1 EQUIPMENT & SUPPLIES: ON-LAND CONSTRUCTION- Wooden Columns

EQUIPMENT	
#	Description
1	Hand Saw
2	Ruler or Tape Measure
3	Square
4	Circular Saw

Table 5.1 Construction Equipment Antenna Tower with Wooden Columns

SAFETY EQUIPMENT	
#	Description
1	Safety glasses
2	Ear plugs
3	Dust mask

Table 5.2 Safety Equipment

SUPPLIES				
#	Description			
		Type	Length ¹	Quantity
1	Wood	4 by 4 treated	16 ft	2
		2 by 4 treated	16 ft	2 or 4 ²

Table 5.3 Construction Supplies for the Antenna Tower Platform with Wooden Columns

¹The length of the 4 by 4 boards will depend on the mean tidal range at the monitoring site. Longer or shorter boards may be required. The 16 foot (4.9 m) long boards work well when the mean high water level is less than 2.5 meters (8.2 ft), with a penetration depth of 2 meters (6.6 ft) or less (there is a correspondence between the penetration depth and the mean high water level that the station can handle).

² Four pieces are used to make a more stable station (see step 6 of 5.5.5.2).

5.5.4.2 EQUIPMENT & SUPPLIES: ON-LAND CONSTRUCTION- PVC Columns

SUPPLIES				
#	Description			
		Type	Length ¹	Quantity
1	PVC pipe (schedule 40)	4 in	10 ft	3 ²

Table 5.4 Construction Supplies for the Antenna Tower Platform with PVC Columns

¹The length of the PVC pipe will depend on the mean tidal range at the monitoring site. Longer or shorter pipes or additional pipes (if extensions are the option) may be required. The 10 foot (3 m) PVC pipes work well when the penetration depth is around 4 to 5 foot (1.2 -1.5 m) and the mean low water less than 5 to 6 foot (1.5 – 1.8 m).

5.5.4.3 EQUIPMENT & SUPPLIES: ON-LAND CONSTRUCTION – Tower System: Guard-Pipe Installed Inside the Antenna Tower

EQUIPMENT	
#	Description
1	Hacksaw
2	Drill
3	Drill Bits
4	Square
5	Ruler/ tape measure
6	Screwdriver or screwdriver bit tips
7	Hammer / hand drilling hammer
8	Thread kit to make a 5/16 thread in PVC pipe

Table 5.5 Construction Equipment for Tower System:
Guard-Pipe Installed Inside the Antenna Tower

SAFETY EQUIPMENT	
#	Description
1	Safety glasses

Table 5.6 Safety Equipment

SUPPLIES				
#	Description			
		Type	Length	Quantity
1	Tower	Galvanized	10 ft	1
	<p>Ten foot galvanized tower section. The upright legs are 1 ¼ (32 mm) round galvanized tubes (outside diameter), while the crossbracing is solid round rod, with an inside equilateral triangle side of 9 5/16 to 10 in. There are several tower manufactures, <i>i.e.</i> Tessco Technologies.</p>			
2	Sensor guard-pipe			
3	Reflectors (<i>i.e.</i> , red round bracketed nail-on Plexiglas reflectors)			Quantity
				3

Table 5.7 Construction Supplies: Tower System – Guard-Pipe Installed Inside the Antenna Tower



SUPPLIES					
Guard-Pipe Inside Tower					
1	6 inch PVC pipe; schedule 40	Length	Quantity		
		6 ft	1		
Two alternatives are presented here to hold the guard-pipe inside the 6" PVC pipe					
Using Hex Head Bolts			Using U Bolts		
					
#	Supplies for Hex Head Bolts				
1	Stainless steel or Galvanized Hex Head Bolts	Length	Diameter	Quantity	
		1-1/2 in	5/16-18	6	
2	Lock nut – stainless steel or galvanized	Type		Quantity	
		5/16-18		12	
#	Supplies for U Bolts				
1	Galvanized U bolts for 4 inch pipe with a minimum length of 8.75 inches.		A	3/8 "	Quantity At least 3
			B	4.5 "	
C	> 1"				
D	> 8.75"				
2	Nut and washers				
NOTE: Bolts, nuts, washers must be of the same material to prevent corrosion.					

Table 5.7 Cont. Construction Supplies: Tower System – Guard-Pipe Installed Inside the Antenna Tower

5.5.4.4 EQUIPMENT & SUPPLIES: DEPLOYMENT - Antenna Tower with Wooden Columns

EQUIPMENT	
#	Tools
1	Hand Saw
2	Hacksaw
3	Sledge hammer
4	Hammer
5	Hand drilling hammer
6	Sockets
7	Combination Wrenches
8	Drill; Drill Bits (need one drill bit of 5.5 in long); screwdriver bit tips
9	Water pump with pipe 16 ft, minimum (if required)
10	Pipe wrenches (if there are multiple pipe extensions)
#	Miscellanies
1	Ruler
2	Square
3	Level
4	Tape Measure
5	Ladder

Table 5.8 Deployment Equipment: Antenna Tower with Wooden Columns

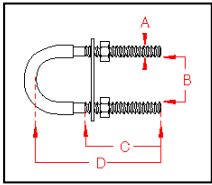
SAFETY EQUIPMENT	
#	Description
1	Safety glasses
2	Gloves

Table 5.9 Safety Equipment

SUPPLIES				
#	Description			
1	Wood	Type	Length	Quantity
		2 by 4 treated	4 ft	2
2	Galvanized carriage bolts	Length	Diameter	Quantity
		8 in	5/16-18	4
3	Two Hole Tubing Strap		1 ¼	At least 4
4	Lag bolts to set the straps on the 4 by 4			At least 8
5	Galvanized screws	2 – 2 ½		
Miscellanies				
1	Reflectors (at least 4)			
2	Station Sign			
3	Marking Flag			
4	Duck tape			
5	Pencil/magic marker			
6	Pieces of wooden boards or other type of cushion to place on top of the 4 by 4 while pounding to prevent splitting			

Table 5.10 Deployment Supplies: Antenna Tower with Wooden Columns

5.5.4.5 EQUIPMENT & SUPPLIES: DEPLOYMENT - Antenna Tower with PVC Columns

EQUIPMENT	
#	Tools
1	Hand Saw
2	Hacksaw
3	Hammer
4	Sledge hammer
5	Hand drilling hammer
6	Sockets
7	Combination Wrenches
8	Drill; Drill Bits (need one drill bit of 5.5 in long); screwdriver bit tips
9	Water pump with pipe 16 ft, minimum (if required).
10	Pipe wrenches (if there are multiple pipe extensions)
PVC Pipe Filling Equipment	
#	Filling: Cement Mix
1	Round point shovel
2	Plastic or other type of container to mix the cement
3	Hoes or other tool to mix the cement
4	Buckets or Containers to carry fresh water
#	Filling: Sand & Gravel
1	Round point shovel
Miscellanies	
1	Ruler
2	Square
3	Level
4	Tape Measure
5	Ladder

Table 5.11 Deployment Equipment: Antenna Tower with PVC Columns

SAFETY EQUIPMENT	
#	Description
1	Safety glasses
2	Gloves

Table 5.12 Safety Equipment

SUPPLIES						
#	Description					
1	Type of material to pour inside the PVC pipes				Quantity ¹	
		Fast setting concrete			8 - 60 lb bags	
		or				
		Sand and Gravel			Five 5 gal buckets (3.6 ft ³)	
2	Galvanized U bolts for 4inch pipe with a minimum length of 6.75 inches.		A	3/8 "	Quantity	
			B	4.5 "	At least 6	
			C	> 1"		
			D	> 6.75"		
3	PVC 4" to 4" couplings. The couplings will be needed if the 10 foot PVC pipes are driven more than 6 ft into the ground. See details in section 5.5.5.2. These couplings are not necessary if the PVC pipes are longer than 10 foot.					
Guard-Pipe Outside Tower						
1	Galvanized U bolts for 4inch pipe with a minimum length of 6.75 inches.				Quantity	
					2	
Miscellanies						
1	PVC glue					
2	Duck tape					
3	Marking Flag					
4	Station Sign					
5	Magic marker					
6	Pieces of wooden boards to be placed on top of the PVC pipes while pounding					

Table 5.13 Deployment Supplies: Antenna Tower with PVC Columns

¹ The quantity may vary depending on the length of the PVC pipe.

5.5.5 CONSTRUCTION & DEPLOYMENT STEPS

The sequential steps followed in the construction of an antenna tower monitoring station can be subdivided into two main activities: construction activities that take place on-land and construction activities that take place on-site (Figure 5.25).

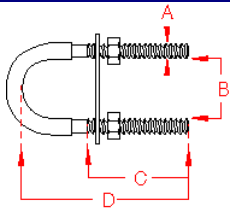
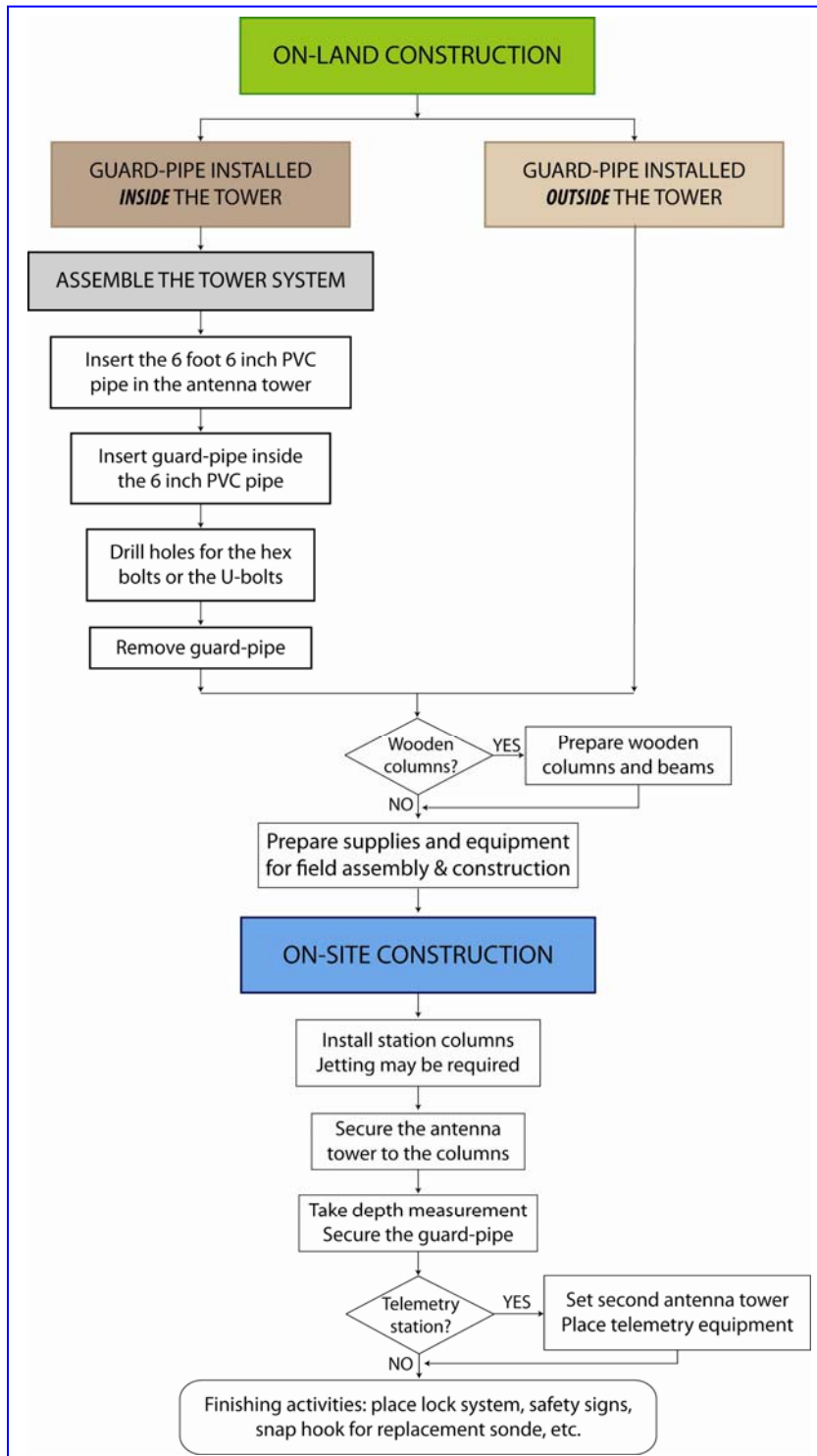

Figure 5.25 Sequential construction steps of an antenna tower station

5.5.5.1 ON-LAND CONSTRUCTION OF THE TOWER SYSTEM: Guard-Pipe Installed Inside the Antenna Tower

Two steps are needed to construct the tower system

1) Place a 6 foot, 6 inch PVC pipe inside the antenna tower

Place the 6 ft long 6 inch PVC pipe at the top-end of the antenna tower and tap it so it slides inside the tower.

This will produce a tight fit between the tower and the PVC pipe.

2) Construct the holding system for the guard-pipe

Two alternatives are presented here.

Holding System: Using Hex Head Bolts

→ Drill three holes, positioned in the pattern of an equilateral triangle, at 5 cm (2 inch) from the top of the PVC pipe using a 7/32 inch drill bit.

→ Using a 5/16 inch thread, thread the three holes (Figure 5.27).

→ Place a 5/16-18 x 1-1/2 bolt in each hole. Put one 5/16-18 lock nut in the outside and one in the inside of the pipe as shown in Figure 5.28.

→ Place the guard-pipe inside the 6 inch PVC pipe until the 4 inch coupling hits the 3 bolts. Check that the guard-pipe is centered with respect to the 6 inch PVC pipe. If not, adjust the bolts so it is centered.

→ Drill three holes at 2.5 cm (1 inch) from the bottom of the 6 inch PVC pipe.

Be sure that the holes do not coincide with the guard-pipe holes. To ensure correct field assembly, draw a guideline once the guard-pipe is set in position; on the 6 inch PVC pipe and on the guard-pipe. This guideline will be used as an alignment reference during field assembly.



Figure 5.26 Inserting 6 foot long 6 in PVC pipe into the antenna tower.



Figure 5.27 Threading top holes.



Figure 5.28 Hex head bolts with two lock nuts.

- Thread the three holes (with a 5/16 inch thread). Place three 5/16-18 x 1-1/2 bolts in the holes. Set one 5/16-18 lock nut in the outside and one in the inside of each bolt (Figure 5.28)
- Remove the guard-pipe.

→ Holding System: Using U-Bolts

- Drill two holes at 5 cm (2 in) from the top of the 6 inch PVC pipe to set an U-bolt (Figure 5.29).
 - The 4 inch coupling will rest on the U-bolt.
 - To drill the holes, employ a long drill bit and use the U-bolt as a guide to ensure the U-bolt will fit into the holes during station assembly.
- Drill two more sets of holes along the 6 inch PVC pipe. The holes must not be vertically aligned to permit a cross fitting (Figure 5.30).
- Place the U-bolts and check that the guard-pipe is well secured.
- Remove U-bolts and guard-pipe.



Figure 5.29 Drilling holes to place U-bolts.



Figure 5.30 View of two U-bolts in a cross position.

5.5.5.2 STATION DEPLOYMENT: ANTENNA TOWER WITH PVC COLUMNS

The deployment instructions are given as guidelines. The specific steps to follow must be evaluated based on each site's particular characteristics.

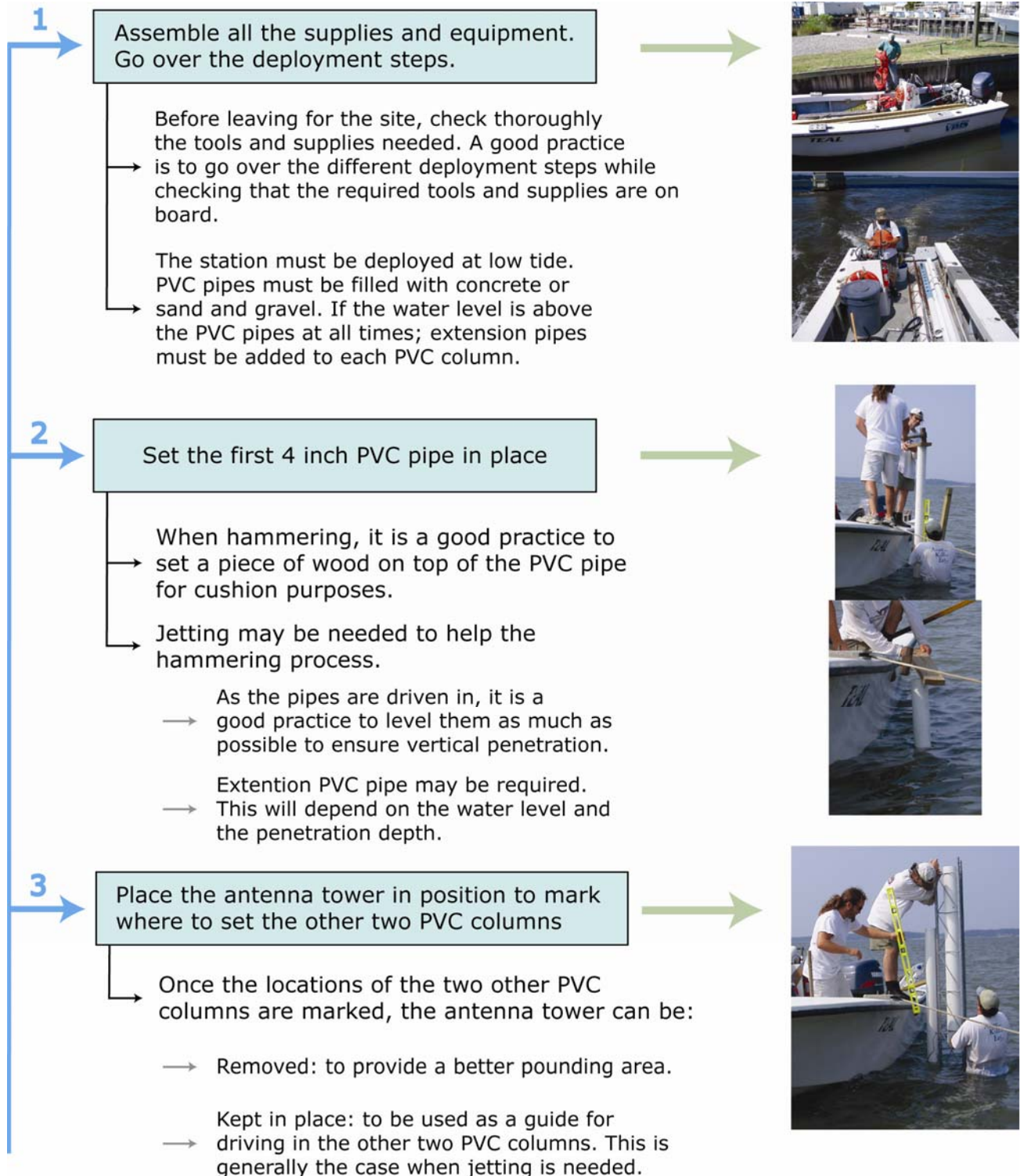

4

Place second and third PVC columns

- At least 1 - 2 foot of pipe must be kept above the water level.
- PVC pipe extensions may be required.



5

Flush the inside of the PVC columns

- The inside of the PVC pipes must be flushed to clean out the sand, mud or any other small debris.
- Set the water pump pressure at minimum. The purpose is to wash the fine particles up and out of the pipes, not to make a hole at the bottom. It is a good practice to insert the jet pipe up to half the length of the PVC during flushing.



6

Pour cement or sand and gravel into each PVC column

- The cement or sand and gravel will displace the water inside the PVC pipes.
- The cement must be mixed with **fresh** water.



7

Secure the antenna tower to the PVC columns

- Install at least 2 U-bolts per column.
- Another option to secure the antenna tower to the PVC columns is by using smaller U-bolts (e.g. 1.75 inch). Even though these type of U-bolts are available in most major home improvement stores, there are certain disadvantages of using them. See the Appendix Section, Appendix 5 for details.



8

Prepare the guard-pipe

- Check the distance that the guard-pipe must be set from the bottom (sampling height).
- Determine if the guard-pipe must be cut or an extension pipe must be added.
- Glue the 4 by 4 coupling on the top of the guard-pipe.



Guard-pipe installed inside the antenna tower

Holding System: U-Bolts

- Set the guard-pipe in position and place the top U-bolt. The 4 by 4 coupling will rest on this U-bolt.
- Place and fasten the other U-bolts.



Holding System: Hex Head Bolts

- Set the guard-pipe in position; align the guidelines (the guidelines were drawn during land assembly).
- The 4 by 4 coupling will rest on the top three hex bolts.
- Fasten the 5/16 - 18 x 1-1/2 bolts so the guard-pipe is centered. Two 1/2 inch combination wrenches can be used for this purpose. Set one wrench on the inside nut and one on the bolt. Tighten the bolts alternatively. Once the guard-pipe is centered, tight the inside and outside nuts on each bolt.
- Once the top hex bolts are secured; the bottom bolts can be fastened. This is a more difficult task given the bolts will be most probably under water.



Guard-pipe installed outside the antenna tower

- Set the guard-pipe in position and place the top U-bolt. The 4 by 4 coupling will rest on this U-bolt.
- Set at least one more U-bolt at a convenient distance from the top U-bolt to secure the guard-pipe to the antenna tower.



9

Telemetry Station

If data will be transmitted using telemetry equipment:

- In most situations a second antenna tower will be needed.
- Part of the telemetry equipment can be pre-installed on the second antenna tower or it can all be installed once the antenna tower is secured.
- Check that the solar panel is placed at the optimum: orientation and tilt angle for the particular location and season.



→ Refer to Chapter 6 for more information on how to install the telemetry equipment.

NOTE: Even though the telemetry equipment is mounted inside a weather resistant control box, it is important to ensure that the control box be above water at all times. Therefore, mean higher high water, wave action and storm surges must be taken into account when mounting the control box (EPA, 2002).

10

Station - Finishing touches

- Place safety signs, paint station, clean the station.



IS A SAFETY STRUCTURE NEEDED AROUND THE STATION ?

The need for a safety structure to protect the monitoring station depends on the following factors:

1. The monitoring site is located in an area where wave action and/or wind can be significant.
2. The maintenance of the station is performed by boat.
3. Maintenance of the sensors must follow a certain schedule independently of weather conditions. Thus, sometimes maintenance has to be performed in weather conditions that are very likely to generate collisions between the boat and station.

In these scenarios, it is a good practice to construct a safety structure where the boat can be moored and collision are prevented. Construction of a simple wooden safety structure is detailed next.

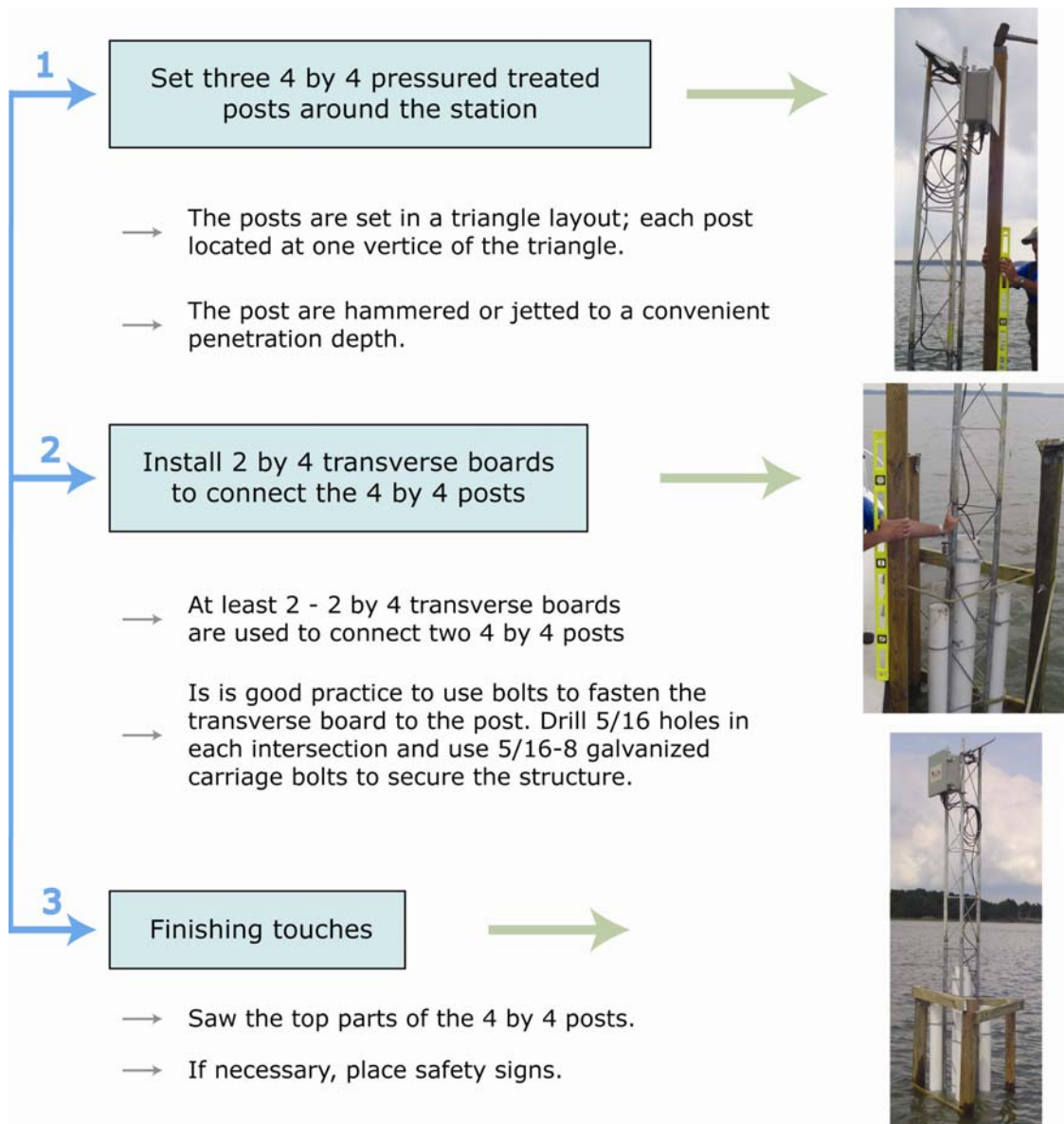

5.5.5.3 STATION DEPLOYMENT: ANTENNA TOWER WITH WOODEN COLUMNS

Brief deployment instructions are given in this section. More detail instructions on how to prepare and install the 4 by 4 post can be found in section 5.6.5.

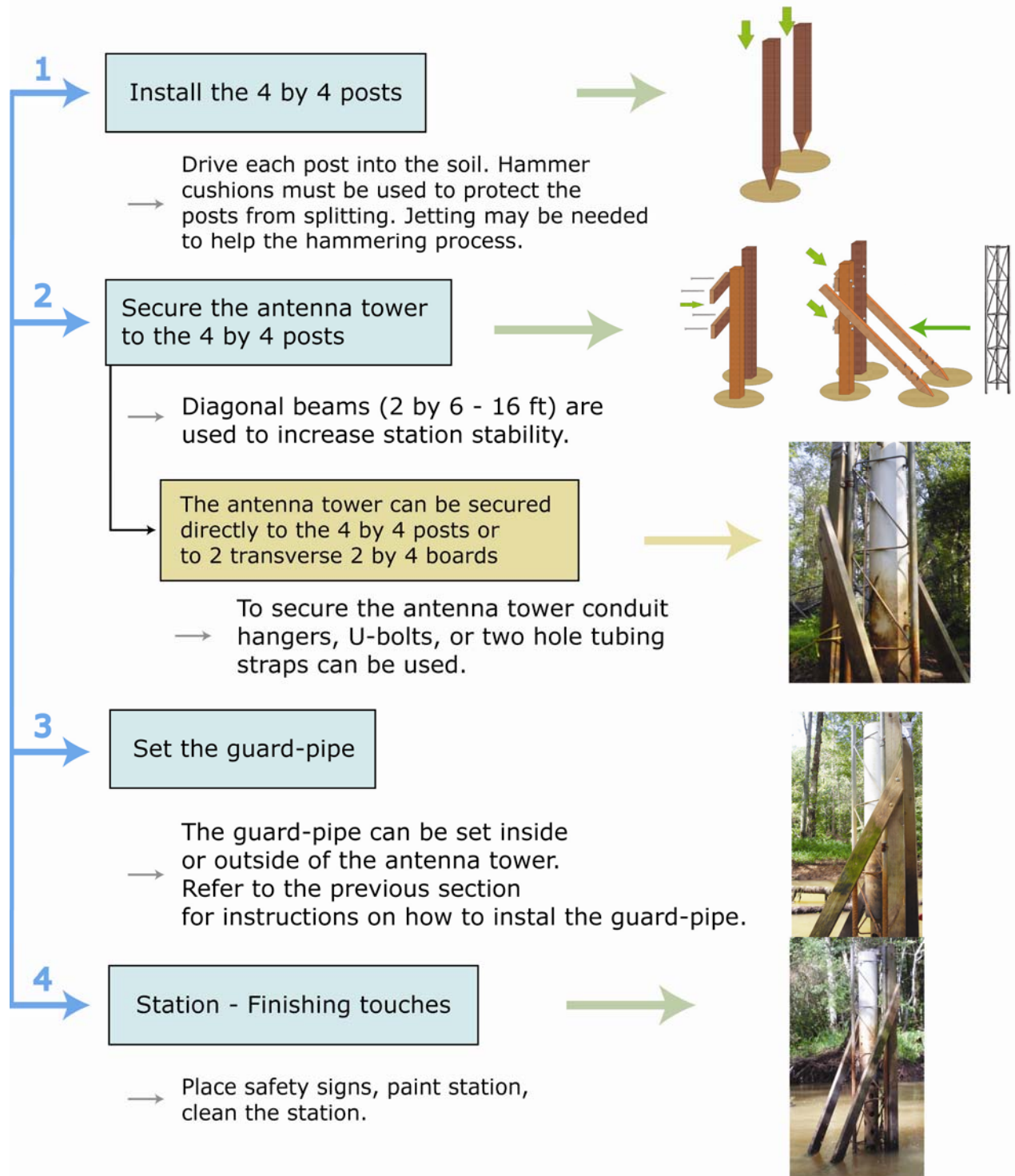

5.6 DESIGNED PLATFORM: WOODEN STRUCTURE

Wood is one of the most frequently construction materials used to built monitoring platforms given it is readily available, is cost effective, has a high strength to weight ratio, and it is very easy to use and work with common tools and fasteners. Therefore, there are many different type of designs of wooden structure platforms. In order to classify these structures, the number of columns was selected as the differentiation parameter (Figure 5.31).

In this section, construction guidelines are provided for a two-column structure used at CBNERRVA. Additional wooden platforms designs are presented at the end of this section for illustrative purpose only.

The guidelines are written in a standard operating procedure style.

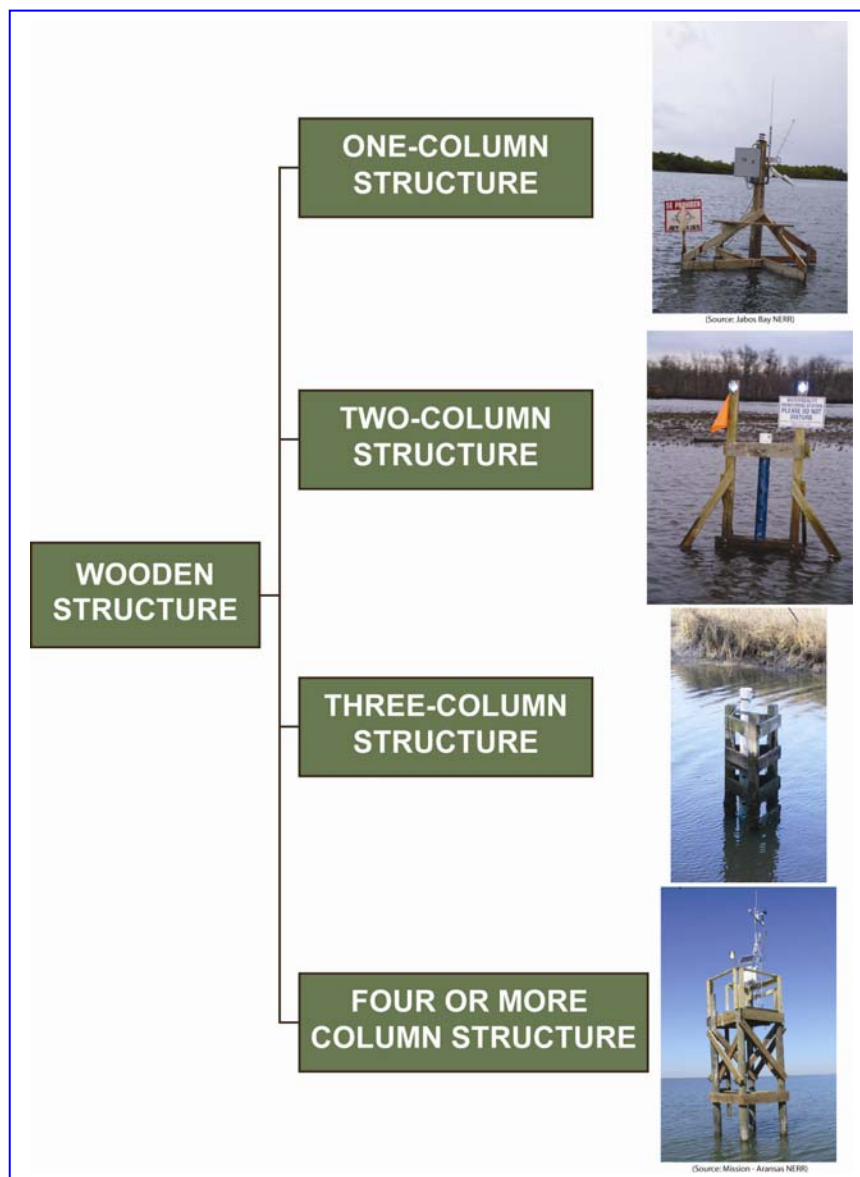

Figure 5.31 Designed platform: wooden structures

5.6.1 SUMMARY OF THE GUIDELINES

A monitoring platform constructed with pressure treated wood is described in this section. The structure is constructed by driving two 16-foot posts (4 by 4 inches thickness) into the ground for use as the platform columns. Transverse 2 by 6 inches boards are employed to secure the 4 by 4 posts and to hold the guard-pipe in place. To further increase the station stability, 16-foot (2 by 6 inches) boards are employed as diagonal beams to support the structure columns. Two basic methods are described to hold the guard-pipe at a fixed position from the bottom substrate.

These guidelines prescribe a specific design method to be followed. The requirements of these guidelines are subject to modification depending on the designer judgment.

5.6.2 QUALIFICATIONS & RESPONSIBILITIES

All users of these guidelines must be familiar with it before implementation and if necessary trained by personnel with previous experience in shallow water quality monitoring station construction.

5.6.3 HEALTH AND SAFETY WARNINGS

The construction of the monitoring structures requires precautions for safe handling and use of the tools and materials.

- General safety precautions for working with electric and power tools must be taken.
- When using power tools safety glasses must be used. When using circular saw earplugs must be used too.
- During field assembly, special care must be taken when using power tools, pumps, hammers, saws, or any other type of tools that can cause injuries. Adequate safety equipment must be used.
- Before field assembly, the construction team must go over the construction steps and safety requirements to assure each team member knows his/her responsibilities.

5.6.4 EQUIPMENT AND SUPPLIES

Two basic wooden platform designs are detailed in this section. The designs differ only on the type of system employed to hold the guard-pipe at a fixed position from the bottom substrate:

- Using wooden boards.
- Using some kind of fastening device (*i.e.* U-bolts, pipe hangers).

The following tables list the equipment and supplies needed to construct and deploy the wooden platforms.

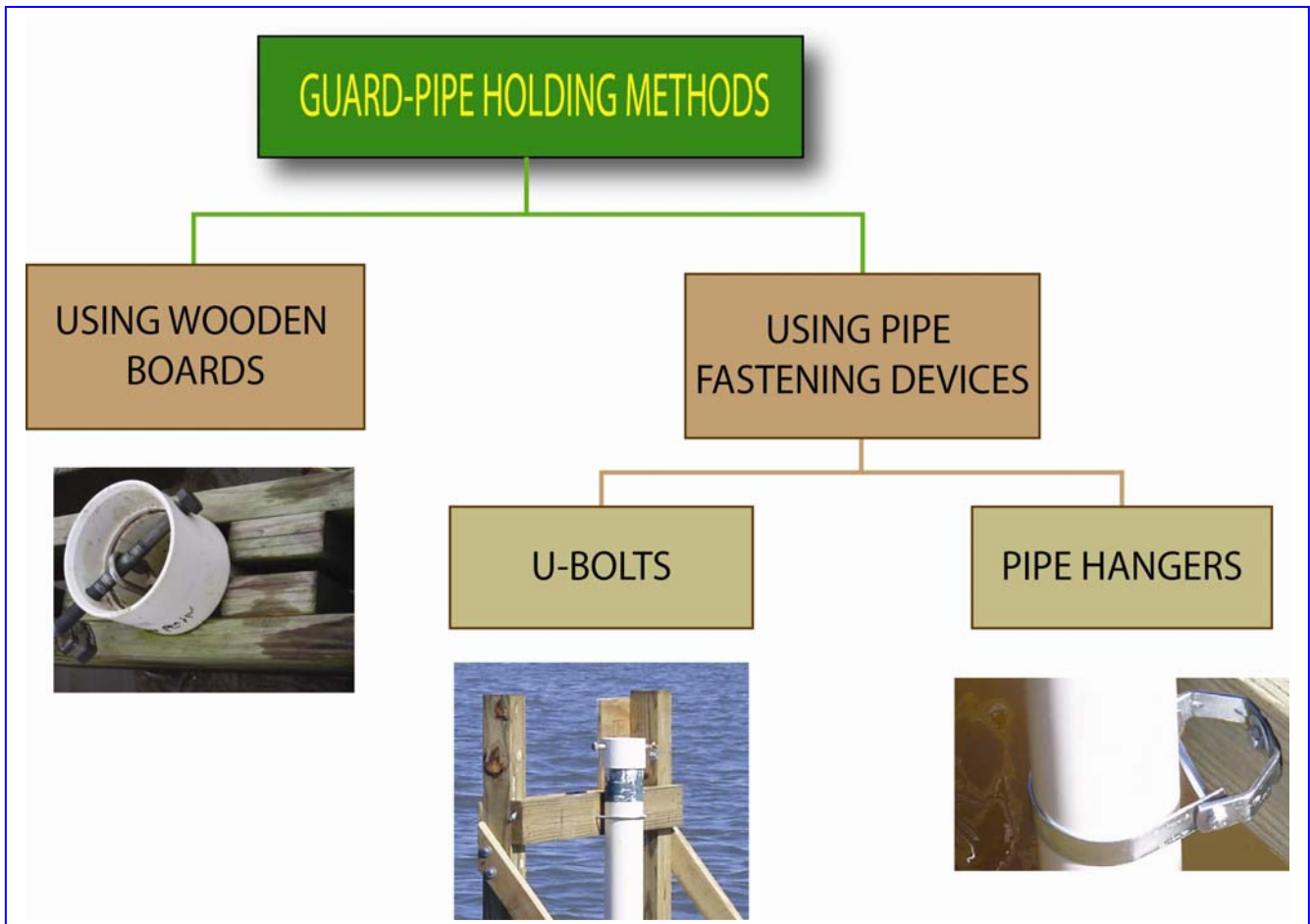

Figure 5.32 Types of guard-pipe holding methods in a wooden platform

5.6.4.1 EQUIPMENT & SUPPLIES: CONSTRUCTION

EQUIPMENT	
#	Description
1	Hand Saw
2	Circular Saw
3	Measuring Tape
4	Square
5	Drill
6	Drill Bits

Table 5.14 Construction Equipment

SAFETY EQUIPMENT	
#	Description
1	Safety glasses
2	Ear plugs
3	Dust mask

Table 5.15 Construction: Safety Equipment

SUPPLIES				
#	Description			
	Wood	Type	Length ¹	Quantity
1	For the station frame	4 by 4 treated	16 ft	2
		2 by 4 treated	16 ft	2 or 4 ²
	GUARD-PIPE HOLDING SYSTEM			
	Using wooden boards to hold the guard-pipe in place	2 by 6 treated	10 ft	2
	Using U-bolts or pipe hangers to hold the guard-pipe in place	2 by 6 treated	10 ft	1
If the guard-pipe holding system is wooden boards, then galvanized screws are needed.				
2	Galvanized screws		Length	Quantity
			2.5 in	At least 10

Table 5.16 – Construction: Supplies

¹The length of the 4 by 4 boards will depend on the mean tidal range at the monitoring site. Longer or shorter boards may be required. The 16 foot (4.9 m) long boards work well when the mean high water level is less than 2.5 meters (8.2 ft) , with a penetration depth of 2 meters (6.6 ft) of less (there is a correspondence between the penetration depth and the mean high water level).

² Four pieces are used to make a more stable station (see step 6 of section 5.5.5.2).

5.6.4.2 EQUIPMENT & SUPPLIES: DEPLOYMENT

EQUIPMENT	
#	Tools
1	Hand Saw
2	Hacksaw
3	Sledge hammer
4	Hammer
5	Hand drilling hammer
6	Combination Wrenches
7	Drill; Drill Bits (6 and a 10 inch long). Screwdriver bit tips
8	Sockets
9	Water pump, pipe 16 ft if available (if required).
10	Pipe wrenches (if there are multiple pipe extensions)

Table 5.17 Assembly & Deployment: Equipment - Tools

EQUIPMENT	
#	Miscellanies
1	Ruler
2	Tape Measure
3	Square
4	Level
5	Ladder

Cont. Table 5.17 Assembly & Deployment: Equipment - Tools

SAFETY EQUIPMENT	
#	Description
1	Safety glasses
2	Gloves

Table 5.18 Assembly & Deployment: Safety Equipment

SUPPLIES						
#	Description					
1	Wood to join and secure the diagonal beams	Type	Length	Quantity		
		2 by 4 treated	4 ft	2		
2	Guard-Pipe					
Holding System: Using wooden boards						
3	Galvanized carriage bolts	Length	Diameter	Quantity		
		8 in	5/16 in	4		
		10 or 12 in	½ in	8		
4	Galvanized screws		2 or 2.5 in			
5	Nuts and washers for the bolts					
Holding System: Using U Bolt or Pipe Hangers						
1	Galvanized carriage bolts	Length	Diameter	Quantity		
		8 in	5/16 in	12		
2	U-bolts or Conduit Hangers	Pipe Ø	Quantity			
		4 in	2			
2	U-bolt specifications				A	3/8 "
					B	4.5 "
					C	> 1"
					D	> 6.75"
#	Miscellanies					
1	Duck tape					
2	Pencil/magic marker					
3	Marking Flag					
4	Station Sign					
5	Reflectors (at least 4) (<i>i.e.</i> , red round bracketed nail-on Plexiglas reflectors					
6	Two or three 2 ft, 2 by 4 pieces of wooden boards to be placed on top of the 4 by 4 while pounding in to prevent their splitting					

Table 5.19 Assembly & Deployment: Supplies

5.6.5 CONSTRUCTION STEPS

The sequential steps followed in the construction of a wooden platform can be subdivided into two main activities: activities that take place on-land and activities that take place on-site.

- **On-Land activities:** Cut the 4 by 4 posts and 2 by 4 diagonal beams so they are ready for deployment; if wooden boards are going to be used to hold the guard-pipe in place, cut and prepare the holding boards.
- **On-Site activities:** all activities to deploy the station; driving the 4 by 4 posts, securing guard-pipe, driving the diagonal beams, *etc.*

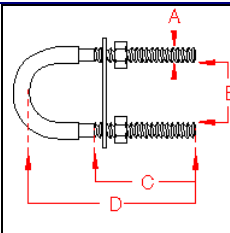
5.6.5.1 PREPARATION OF THE 4 BY 4 POSTS AND DIAGONAL BEAMS

The construction steps are simple and straightforward. Basically the procedure consists of two steps:

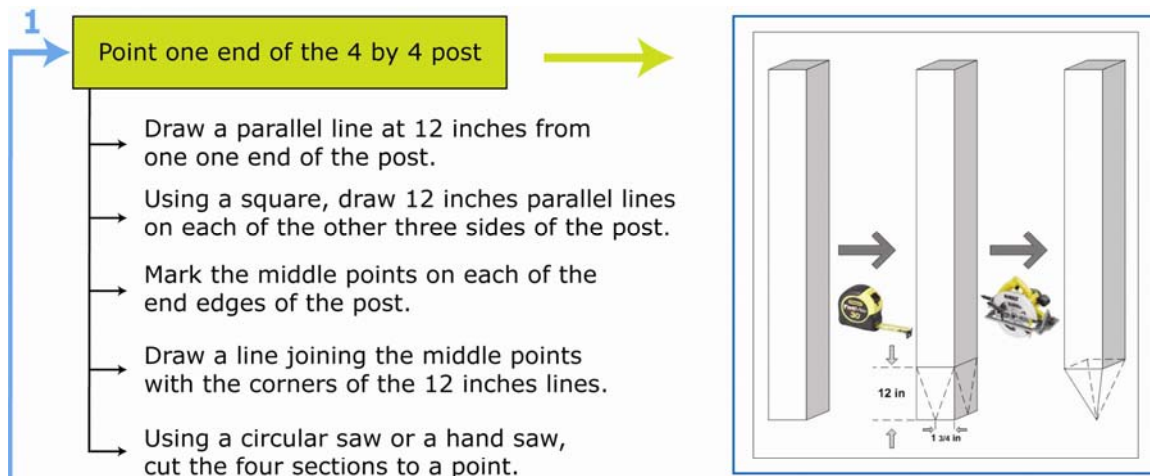

Figure 5.33 Cutting end points on the 4 by 4 posts.

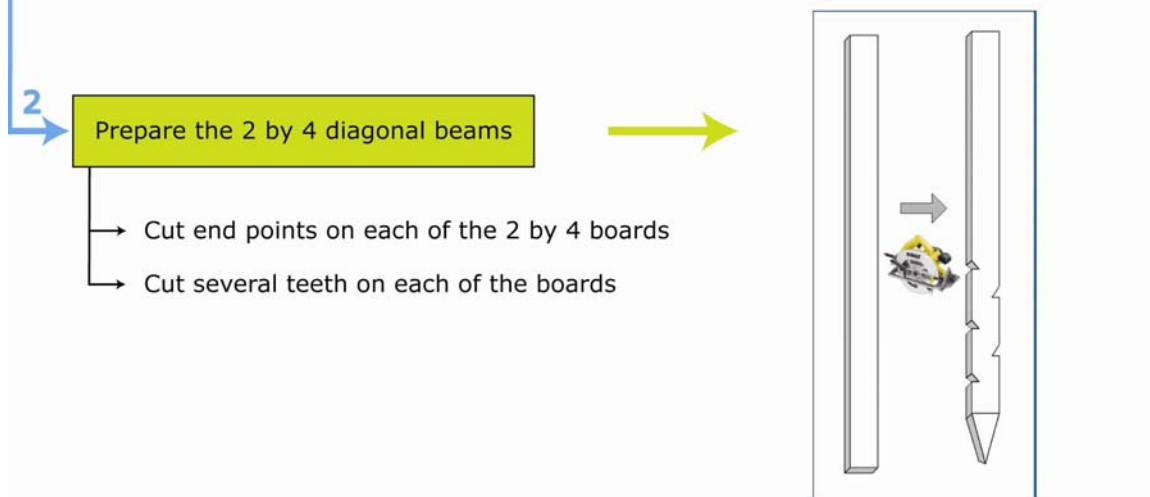

Figure 5.34 Cutting end points and teeth on the 2 by 4 boards.

5.6.5.2 PREPARATION OF THE GUARD-PIPE HOLDING SYSTEM MADE WOODEN BOARDS

The construction steps are simple and straightforward. Basically the procedure consists of three steps:

1 → Mark the 2 by 6s boards for cutting

- Cut 2 - 4 foot long - 2 by 6s.
- Cut 2 - 5 foot long - 2 by 6s.
- On each piece mark the following lines (as shown in Figure 5.35).
 - The middle line.
 - Two lines on each side of the middle line at a distance of 1 1/4 inches.
 - Two lines on each side of the middle line at a distance of 1 3/4 inches.
 - Two lines on each side of the middle line at a distance of 2 1/4 inches.

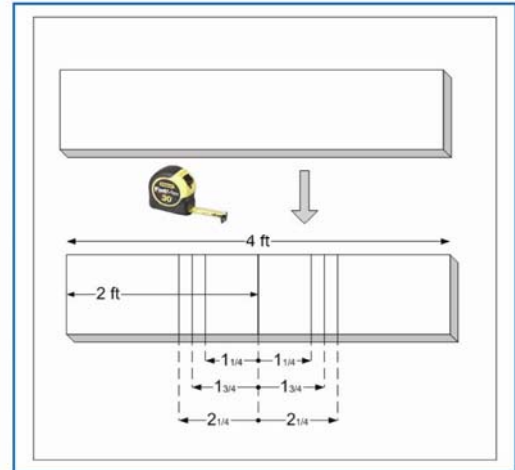

Figure 5.35 Marking the 4 foot long 2 by 6s board for cutting.

2 → Cut two openings in each 2 by 6s

- Using a circular saw make the following openings.
 - Between the 1 1/4 inch lines cut with a circular saw an opening of 1/2 inch deep.
 - Between the 1 1/4 inch line and the 1 3/4 inch line, make an opening of 1/4 inch deep.

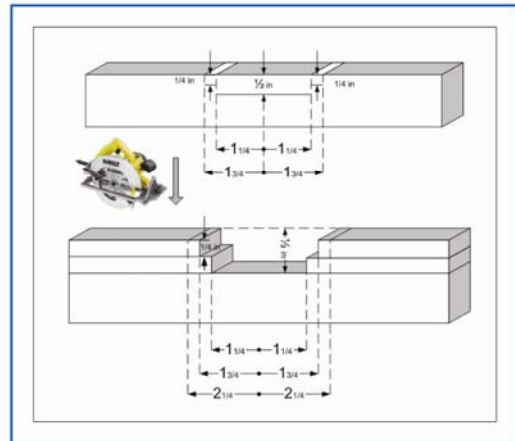

Figure 5.36 Cutting openings on each board.

3 → Screw 2 - 6 inch long - 2 by 6s on each board

- Cut 8 - 6 inch long - 2 by 6s.
- Screw 2 pieces per board, one on each side of the 2 1/4 inch line.

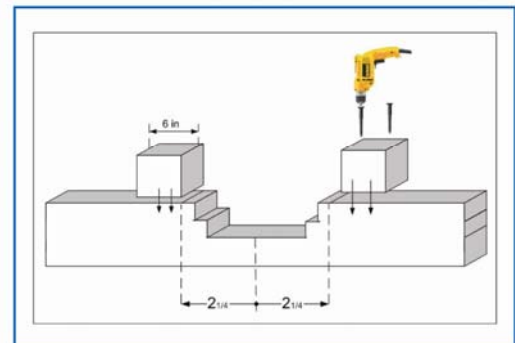

Figure 5.37 Screwing 6 in long - 2 by 6s

5.6.5.3 STATION DEPLOYMENT

The deployment of the wooden platforms is basically independent of the type of guard-pipe holding system. The sequential steps to deploy each type of platform design are briefly shown in Figures 5.38 and 5.39.

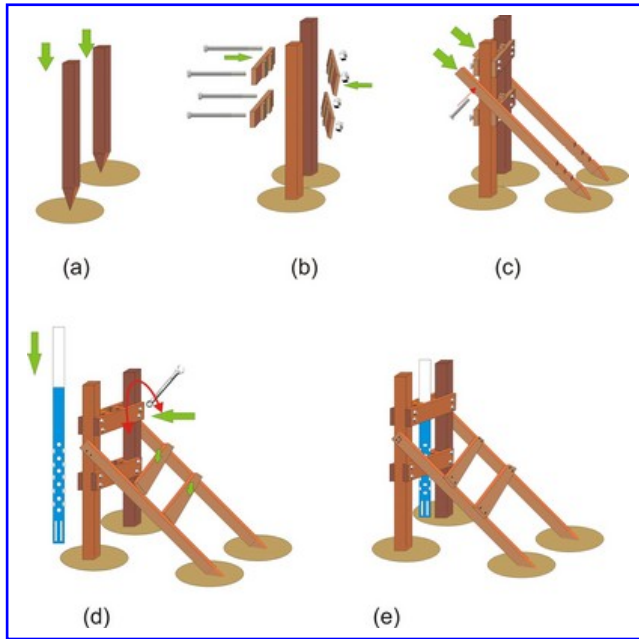

Figure 5.38 Sketch showing the deployment steps of a wooden platform that employs wooden boards to hold the guard-pipe in place.

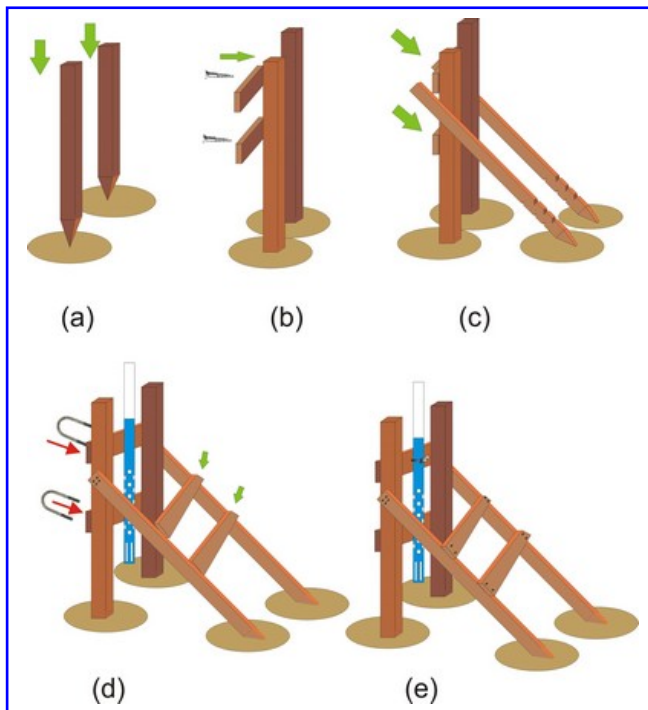
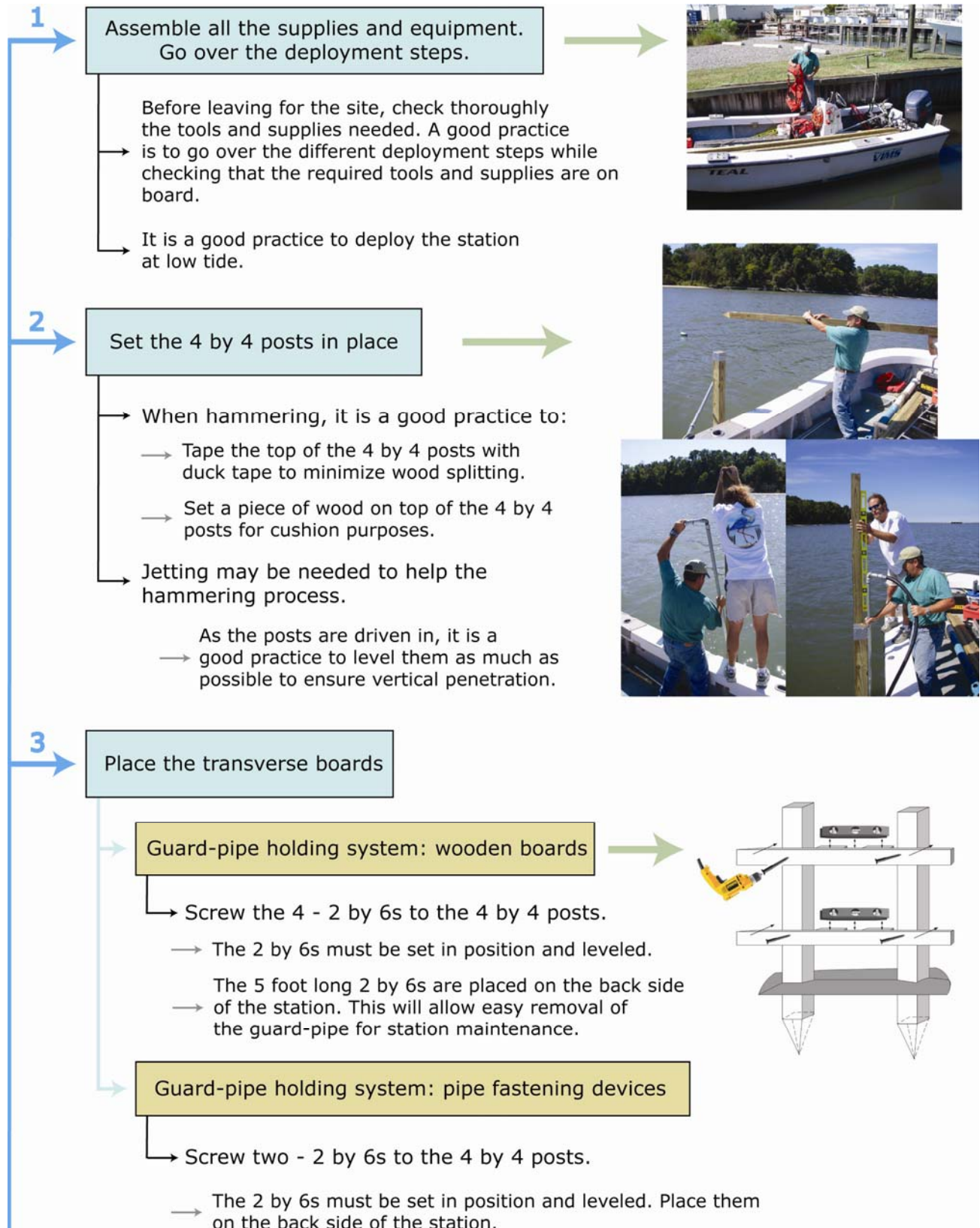

Figure 5.39 Sketch showing the deployment steps of a wooden platform using U-bolts to hold the guard-pipe in place.

The deployment instructions are given as guidelines only. The specific steps to follow must be evaluated based on each site's particular characteristics.



4

Place the diagonal beams

- It is a good practice to duck tape the top of the 2 by 4 to minimize wood splitting.
- Drill 2- 5/16 holes at each (diagonal beam) - (4 by 4) intersection.
- Using a hammer, drive a 5/16-8 galvanized carriage bolt into each hole; place washer and nut; tighten the nuts.
 - To increase the stability of the station, 4 diagonal beams may be used.



5

Place the guard-pipe

Guard-pipe holding system: wooden boards

- Drill 2- 1/2 holes at each (2 by 6) - (4 by 4) intersection.
- Using a hammer, drive a 1/2 - 10 or 12 galvanized carriage bolt into each hole; place washer and nut.
 - The bolts must be facing toward the back side of the station.
- Check the distance that the guard-pipe must be set from the bottom (sampling height).
- Determine if the guard-pipe has to be cut or an extension pipe must be added (the 4 by 4 coupling will rest on top of the 2 by 6s). Glue the 4 by 4 coupling to the guard-pipe.
- Set the guard-pipe inside the holding boards; tighten the nuts.



Guard-pipe holding system: using pipe fastening devices

- Check the distance that the guard-pipe must be set from the bottom (sampling height).
- Determine if the guard-pipe has to be cut or an extension pipe must be added. Glue the 4 by 4 coupling to the guard-pipe.
- Place one fastening device on each 2 by 6.
- Place the guard-pipe in position and tighten the U-bolt or pipe hanger.
- Place 2 - 2 by 6s on the front part of the station, parallel to the 2 by 6s that hold the guard-pipe. Screw them.
- Drill 2- 1/2 holes at each (2 by 6) - (4 by 4) intersection.
- Using a hammer, drive a 1/2- 10 or 12 inch galvanized carriage bolt into each hole; place washer and nut.
 - The bolts must be facing toward the back side of the station.



6

Station - Finishing touches

- Place safety signs, paint station, clean the station.



5.6.6 OTHER TYPES OF WOODEN PLATFORMS

The following illustrations are provided as examples of other types of wooden monitoring platforms.



Figure 5.40 One-column structure
(Source: Jobos Bay, NERR)



Figure 5.41 Three-column structure
(Source: Taskinas Creek, NERRVA)



Figure 5.42 Four-column structure
(Source: USGS South Florida Information Access)



Figure 5.43 Four-column structure
(Source: Mission-Aransas NERR)

5.7 EXISTING STRUCTURES

Existing structures are all the different types of structures that already exist at the monitoring sites and the user takes advantage of them to set the monitoring station.

The existing structures are subdivided into four main categories:

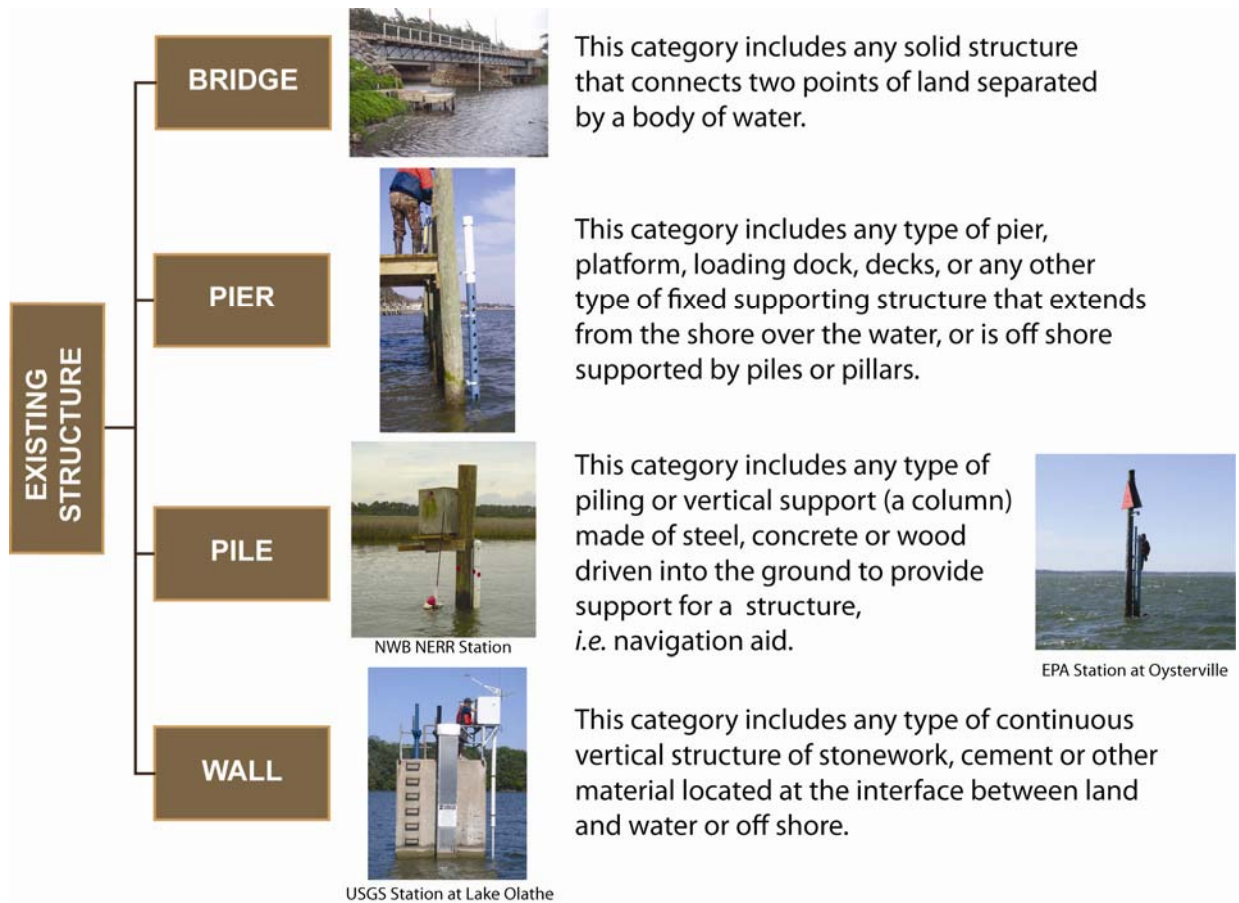
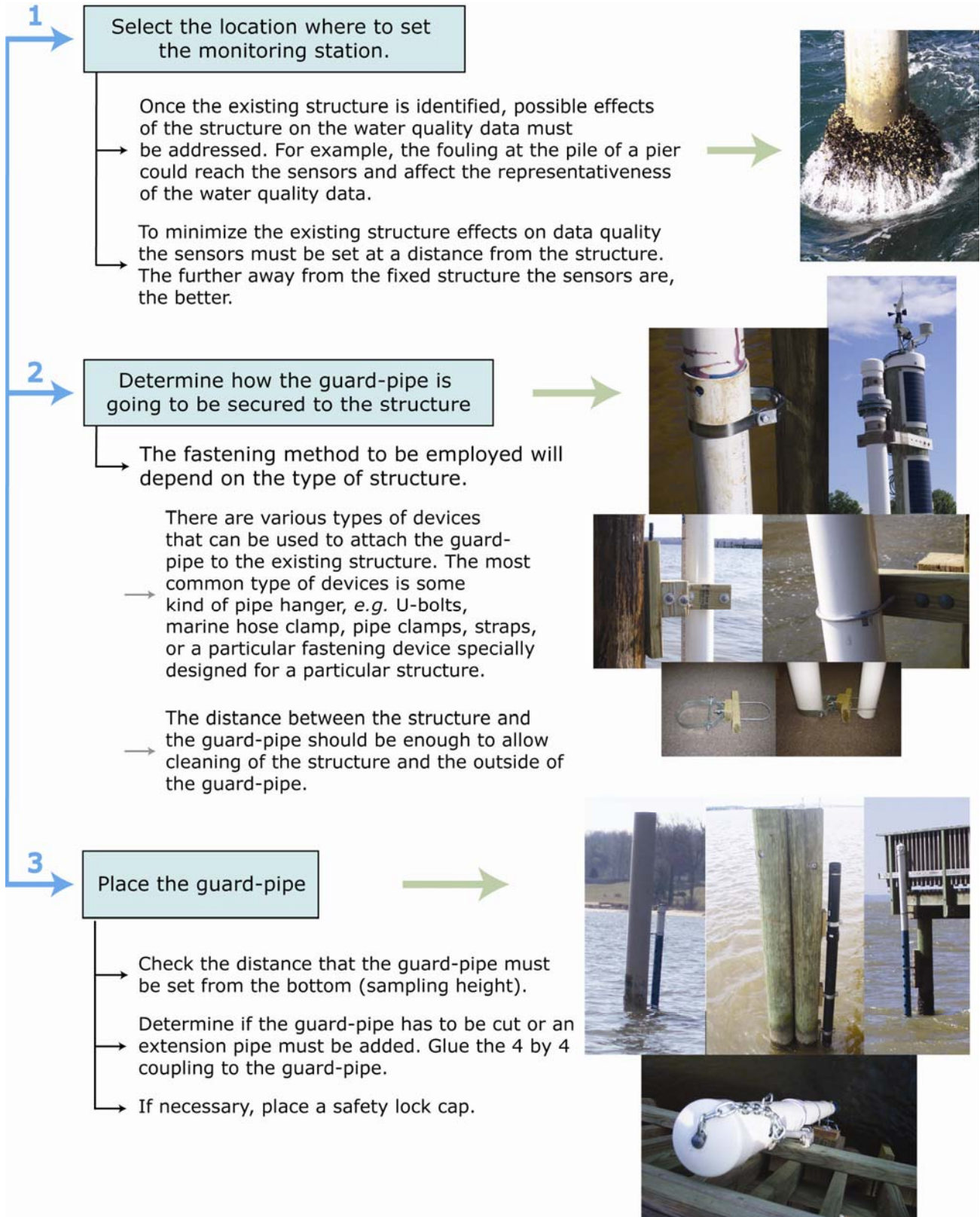

Figure 5.44 Existing Structures

Attaching the guard-pipe to an existing structure has its advantages and disadvantages. Advantages include ease of setting (cost/effort of installation is much less than an offshore-based station) and accessibility (the station can be accessed independent of weather conditions in most structures). The main disadvantage of this type of station is that the location of the existing structure cannot be changed. Once it is decided that an existing structure will be used (*i.e.* the station must be placed on a pier due to budget constraints); then an existing structure at the sampling site must be found where the monitoring objectives are fulfilled, and representative data can be collected.

The construction steps to secure the guard-pipe to an existing structure are simple and straightforward. Basically the procedure consists of three steps:



5.8 ON RIVER & STREAM BANK

5.8.1 ON RIVER & STREAM BANK: WITH EQUIPMENT SHELTER

On river and stream bank water quality monitoring stations with equipment shelter can be classified as flow-through and in-situ monitoring systems.

5.8.8.1 Flow-Through Monitoring System

In a flow-through system the surface water is pumped to a container mounted in a shelter where the multiparameter sonde is located. The water is then released by gravity back to the river or stream (Wagner *et al.*, 2006).

The flow-through configuration is commonly employed in sampling locations where the monitoring sensor can not be installed safely in the river or stream (BC Ministry of Environment, 2007). Environmental conditions that make propitious the application of a flow-through system are detailed in Table 5.20.

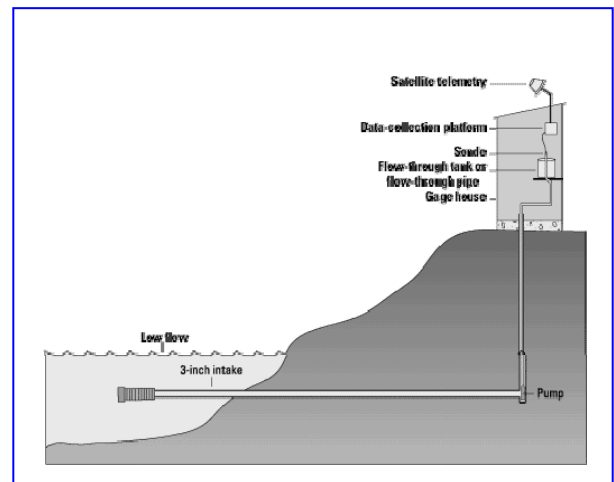
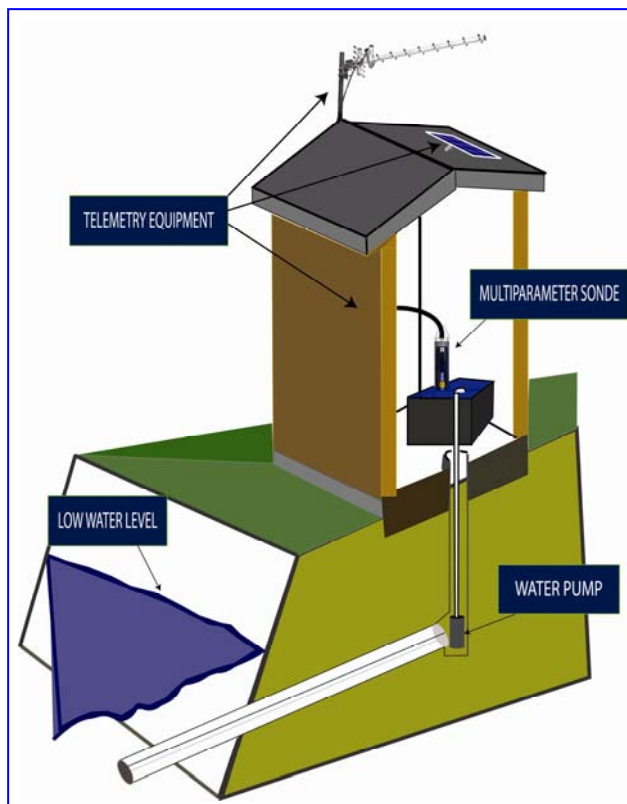

Figure 5.45 Flow-through monitoring system (Source: Wagner *et al.*, 2000)



Excessive turbulence and bubbles
Extreme danger of instrument damage from floating debris or bedload
Insufficient water depth to meet operational requirements
Unstable bank conditions or no structure available to anchor a deployment tube
Severe cold and ice during the winter

Table 5.20 Environmental conditions that make propitious the application of a flow-through system (Source: BC Ministry of Environment, 2007)

Figure 5.46 Sketch of flow-through monitoring system

5.8.8.2 In-Situ Monitoring System

In an in-situ monitoring system the sensors are placed at the measuring point in the river or stream cross section (Wagner *et al.*, 2006).

General construction guidelines for the flow-through and in-situ monitoring systems can be found in Wagner *et al.*, 2006 and in BC Ministry of Environment, 2007. Advantages and disadvantages of each type of structure are given in these publications. These guidelines will enable the monitoring team to construct or design shelter type monitoring structures. Guidelines on how to secure the guard-pipe to the bank are given in the next section.

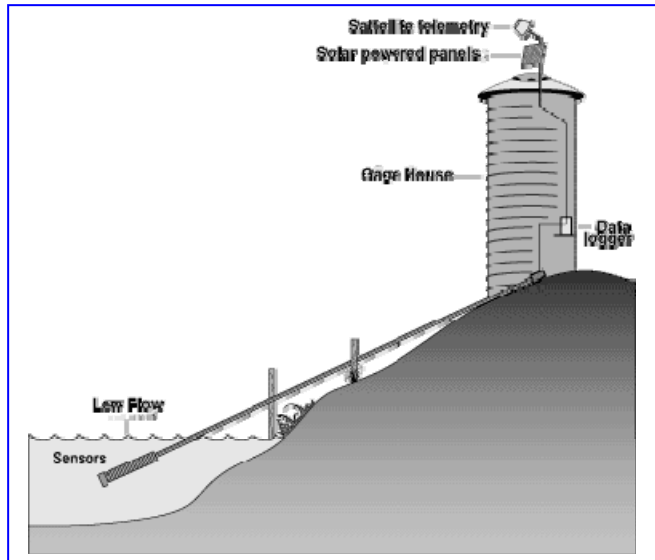

Figure 5.47 In-situ monitoring system with shelter
(Source: Wagner *et al.*, 2000)



Figure 5.48 USGS monitoring station at Pete Mitchell Swamp, NC.
(Source: USGS North Carolina Water Science Center)



Figure 5.49 USGS monitoring station
at Spring Brook Creek, WA.
(Source: USGS Washington Water Science Center)

In-situ monitoring stations with shelter are a good option when monitoring equipment must be protected from the weather, and/or certain field tasks need protection from the weather for their execution. In addition, the shelter provides added protection from vandalism.

5.8.2 ON RIVER & STREAM BANK: WITHOUT EQUIPMENT SHELTER

On river and stream bank water quality monitoring stations without equipment shelter are basically composed of a guard-pipe secured to the bank on an angle (same layout as the in-situ monitoring system with shelter, in this case, without the shelter).

Different methods exist to secure the guard-pipe to the bank, going from special designed structures to using the trees at the site to anchor the guard-pipe. The following illustrations can be used as guidelines to select or design an on river & stream bank station.

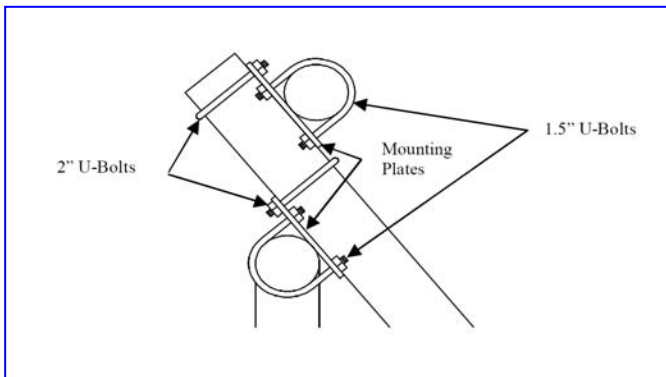

Figure 5.50 PVC pipe – U bolts mounting system
(Source: YSI Incorporated)



Figure 5.51 Lying on the bank
(Source: USGS, Tongue River, MT)



Figure 5.52 Cement foundation, pipe,
pipe fasteners mounting system
(Source: Universiti Sains Malaysia)



Figure 5.53 Wood post & steel pipe structure
(Source: New South Wales Department of Natural Resources, Lower Richmond)

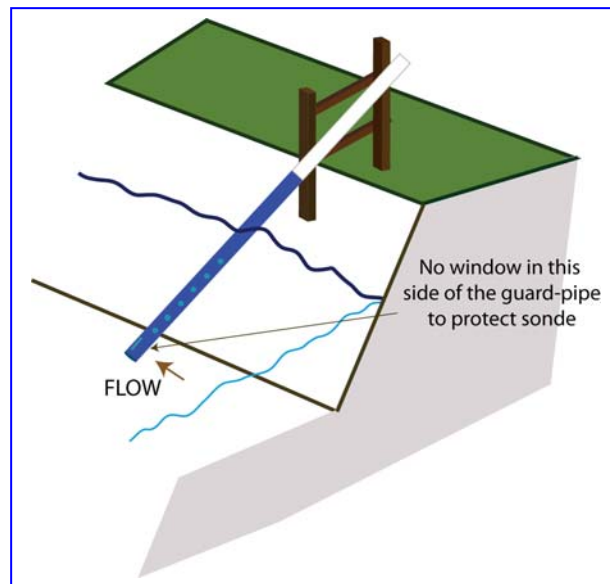

Figure 5.54 Wooden structure

5.9 REFERENCE

Ascalew Abebe and Ian GN Smith. 2005. **Pile Foundation Design: A Student Guide**. School of the Built Environment, Napier University, Edinburgh. <http://www.sbe.napier.ac.uk/projects/piledesign/guide/index.htm>

BC Ministry of Environment. 2007. **Continuous Water-Quality Sampling Programs: Operating Procedures**. Watershed and Aquifer Science. Science and Information Branch. The Province of British Columbia. Resources Information Standard Committee.

Collin James G. 2002. **Timber Pile Design and Construction Manual**. American Wood Preservers Institute (AWPI).

Department of the Army. 1985. **Pile Construction**. Field Manual No. 5-134.

Federal Highway Administration (FHWA). 2007. **Pile Driving Inspector's Tutorial**. United States Department of Transportation. Transportation Curriculum Coordination Council.

Gerwick Ben C. 2000. **Construction of Marine and Offshore Structures**. Second Edition. CRC Press.

Kelty, Ruth and Steve Bliven. 2003. **Environmental and Aesthetic Impacts of Small Docks and Piers: Workshop Report: Developing a Science-Based Decision Support Tool for Small Dock Management, Phase 1: Status of the Science**. NOAA Coastal Ocean Program, Decision Analysis Series Number 22. NOAA Coastal Ocean Program, 1305 East-West Highway, Silver Spring, MD, 20910.

Miles, Eduardo J. 2008. **The SSC cycle: a PDCA approach to address site-specific characteristics in a continuous shallow water quality monitoring project**. Journal of Environmental Monitoring:10, 604 – 611. DOI: 10.1039/b717406c.

Osmond Deanna L., Grace R. Lawrence, and Janet Young. 2003. **Dock and Pier Construction in Coastal Communities**. Environmental Stewardship for Homeowners #6 NORTH CAROLINA COOPERATIVE EXTENSION SERVICE. AG-565-01.

Shroff Arvind V. and Dhananjay L. Shah. 2003. **Soil Mechanics and Geotechnical Engineering**. Taylor & Francis.

The Hong Kong Polytechnic University. **Pile Foundations**. Department of Civil and Structural Engineering. <http://www.cse.polyu.edu.hk/~ctpile/frame/frame.html>

Tomlinson Michael J. 1994. **Pile Design and Construction Practice**. Taylor & Francis. London & New York.

US Army Corps of Engineers. 2003. **Wood Marine Piles**. UFGS-31 62 19.13

US Army Corps of Engineers. 1998. **Pile Driving Equipment**. Technical Instructions. TI 818-03.

U.S. Environmental Protection Agency. 2002. **Delivering Timely Water Quality Information to Your Community**. The Chesapeake Bay and National Aquarium in Baltimore EMPACT Projects. Office of Research and Development. National Risk Management Research Laboratory Cincinnati. EPA625/R-02/018

Wagner, Richard J., and Robert W. Boulger, Jr., Carolyn J. Oblinger, and Brett A. Smith. 2000. **Guidelines and Standard Procedures for Continuous Water-Quality Monitors: Station Operation, Record Computation, and Data Reporting**. U.S. Geological Survey. Techniques and Methods 1–D3. <http://pubs.usgs.gov/tm/2006/tm1D3/pdf/TM1D3.pdf>

5.9.1 Photo Reference

Figure 5.3 - Federal Highway Administration (FHWA). 2007. Pile Driving Inspector's Tutorial. United States Department of Transportation. Transportation Curriculum Coordination Council. <http://www.fhwa.dot.gov/infrastructure/tccc/tutorial/piles/pile03d.htm>

Figure 5.4 - Whatcom Waterfront Construction. <http://whatcomwaterfrontconstruction.com/>

Figure 5.5 - ASD Commercial Diving and Marine Contractors <http://www.asddiving.com.au/>
Marine Pile Drivers <http://www.marinepiledrivers.com/?gclid=CKeS9ob43ZoCFQQRswodUgojzQ>

Figure 5.19 - Paul Perusse <http://www.kayakvb.com/reports/>

Figure 5.21 – T. Chris Mochon-Collura. Eelgrass Research, Hood Canal, WA. Region 10: The Pacific Northwest. U.S. Environmental Protection Agency. <http://yosemite.epa.gov/r10/OEA.NSF/Investigations/Dive+BOS>

Figure 5.42 - Open-water ET site in ENR (2). Evapotranspiration Measurements and Modeling in the Everglades. US Geological Survey South Florida Information Access. http://sofia.usgs.gov/projects/index.php?project_url=evapotrans

Figure 5.44 - Oysterville Station. Coastal Estuary Instrument Maintenance and Recovery, Willapa Bay, WA. Region 10: The Pacific Northwest. U.S. Environmental Protection Agency. <http://yosemite.epa.gov/r10/OEA.NSF/Investigations/Dive+BOS>

Figure 5.45 - Wagner, Richard J., and Robert W. Boulger, Jr., Carolyn J. Oblinger, and Brett A. Smith. 2000. Guidelines and Standard Procedures for Continuous Water-Quality Monitors: Station Operation, Record Computation, and Data Reporting. U.S. Geological Survey. Techniques and Methods 1–D3.

Figure 5.47 - Wagner, Richard J., and Robert W. Boulger, Jr., Carolyn J. Oblinger, and Brett A. Smith. 2006. Guidelines and Standard Procedures for Continuous Water-Quality Monitors: Station Operation, Record Computation, and Data Reporting. U.S. Geological Survey. Techniques and Methods 1–D3.

<http://pubs.usgs.gov/tm/2006/tm1D3/pdf/TM1D3.pdf>

Figure 5.48 - Albemarle-Pamlico Study (ALBE), National Water-Quality Assessment (NAWQA). Station Photos 1991-2000. Pete Mitchell Swamp. Albemarle-Pamlico NAWQA. US Geological Survey North Carolina Water Science Center.

<http://nc.water.usgs.gov/albe/index.html>

Figure 5.49 - 12113346 Spring Brook Creek near Orillia Station. US Geological Survey Washington Water Science Center.

<http://wa.water.usgs.gov/cgi/adr.cgi?12113346>

Figure 5.50. - 5200 Continuous Monitor Operations Manual. YSI Incorporated.

https://www.ysi.com/DocumentServer/DocumentServer?docID=WQS_5200_MANUAL

Figure 5.51 Tongue River Surface-Water-Quality Monitoring Network. US Geological Survey Gaging Station at Tongue River at State Line.

<http://mt.water.usgs.gov/projects/tongueriver/saranalyzer.htm>

Figure 5.52 - Wetpond Station (Sonde 1) and Wetland Micro pool Station (Sonde 2). Water Quantity and Quality Monitoring Station. Application of Bio-Ecological Drainage System (BIOECODS) in Malaysia. River Engineering and Urban Drainage. Universiti Sains Malaysia. <http://redac.eng.usm.my/html/projects/bioecods/>

Figure 5.53 Water Quality Monitoring Station On Coastal Wetland Drain, Tuckean Swamp. Managing Connected Water Resources Project. New South Wales Department of Natural Resources. Australian Government.

<http://www.connectedwater.gov.au/index.html>